

Technical Data



UNINTERRUPTIBLE POWER SUPPLY

SERIES USPRD 1000 – 3000VA

1/1 PHASE

On Line / Double Conversion (VFI) Technology

CONTENTS

| | |
|---|-----------|
| <u>GENERAL DESCRIPTION</u> | 3 |
| <i>THE USPRD UPS</i> | 3 |
| <u>STANDARD VERSIONS</u> | 4 |
| <u>ER VERSIONS FOR EXTENDED AUTONOMY</u> | 4 |
| <i>X05 BATTERY BOX</i> | 5 |
| <u>APPEARANCE AND ACCESSORIES</u> | 6 |
| <u>DISPLAY</u> | 7 |
| <u>GENERIC ACCESSORIES</u> | 8 |
| <i>MULTIPASS</i> | 8 |
| <i>OPTIONAL SLOT CARDS</i> | 8 |
| <i>FRONTAL VIEW</i> | 9 |
| <i>REAR VIEWS</i> | 10 |
| <i>CERTIFICATIONS</i> | 11 |
| <u>TECHNICAL DATA TABLE</u> | 12 |
| <u>COMMUNICATION PORTS AND FIRMWARE</u> | 14 |
| <i>RS 232 CONNECTOR</i> | 14 |
| <i>TECHNICAL DATA FOR “PIN 6” POWER THROUGH THE RS 232 PORT</i> | 15 |
| <u>FIRMWARE</u> | 15 |

GENERAL DESCRIPTION

THE USPRD UPS

The USPRD UPS is an online single-phase unit for tower/rack installation.

The units are available with power ratings of 1000VA-1500VA-2200VA-3000VA, with an output power factor equal to 0.9.

The units with power ratings of 2200VA and 3000VA are also available in relative ER (extended autonomy) versions, with a high-powered 6A battery charger in place of the battery tray.

The 1500VA version is not equipped with extended autonomy.

The UPS is designed to be configured for various operating modes:

- **ON-LINE** is the operating mode which offers maximum load protection and the best output waveform quality (*)
- **ECO** is the operating mode which offers the least UPS consumption, or rather maximum efficiency (**)
- **SMART ACTIVE** is the operating mode which allows the UPS to decide whether to enable ON-LINE or ECO functionality, based on a statistic regarding the quality of the Power Supply network.
- **STAND-BY OFF [Mode 1]** is the operating mode in which the UPS functions as an emergency device. While power is present the UPS does not intervene. In the event of a blackout, the necessary power is provided by the UPS.

(*) the effective values (rms) of the voltage and the output frequency are constantly controlled by the microprocessor independently with respect to the waveform of the network voltage, thereby maintaining the output frequency synchronized with the network within a configurable interval.

Outside of this interval, the UPS eliminates its synchronism with the network and brings itself to its nominal frequency; under these conditions, the UPS cannot utilize the bypass.

(**) In order to optimize yield, the load is normally powered by the bypass in ECO mode. In the event that the network should move outside of the preset tolerances, the UPS will switch to ON LINE functionality. Once the network has moved back within the preset tolerances for at least five minutes, the UPS will go back to powering the load through the bypass.

The internal battery tray is of a hot-swap typology and the connector is secured to the test finger and the pin based on the requirements of the TUV.

The battery tray can be replaced using the manual bypass function. This function can be enabled by pressing and holding down the ON and SEL keys for 4 seconds.

The display is of a positive typology (white background with black lettering). For this reason, in order to avoid unnecessary power consumption, the display's backlighting must be turned off when it is not in use.

As already indicated above, the unit's structure is designed for both Tower and Rack installation, with a hot-swap battery tray. The UPS unit is 2U and comes supplied with support feet for the tower installation. The unit is front and rear ventilated in order to allow for rack installation and, in the case of tower installation, to allow for the battery box or other equipment to be positioned laterally.

The UPS unit's onboard communications are comprised of: an RS232 serial port, a USB port (not for simultaneous use) and a slot for additional communication cards (with a second serial port independent from the first). The serial port also contains 3 opto-isolated outputs whose functionalities can be programmed using the UpsTools configuration software. Every version is equipped with a rear 3-pole connector which, by default, performs the R.E.P.O. and Remote ON functions.

The UPS unit's control card has an onboard E²PROM in order to allow for various information to be saved, including the unit's settings, backlog data, calibration data, etc.

The unit's operating mode can be set directly from the display. The firmware of the UPS unit can be reprogrammed on site using the appropriate programming card.

Inverter/bypass switching only takes place in the case of the inverter's final shutdown or in the event of continuous overloading.

The front panel has a main switch (1/0) which can be used to disconnect the entire UPS unit, for example, in cases of prolonged disuse. In addition to ensuring that the entire unit has been disconnected, this

switch also serves an important energy saving function, for example, in structures where various small UPS units have been installed. It is also useful in the case of rack installation where the rear portion of the device cannot be accessed in order to disconnect the cables.

“Cold starts” (activation using the batteries) can even be performed at full charge.

The 2200VA and 3000VA versions are equipped with Energy Share sockets, which can be setup using the UpsTools configuration software. An icon on the display indicates the status of the Energy Share sockets.

The speed of the fans is regulated by means of a dedicated variable continuous power supply in order to reduce noise levels and increase the reliability of the fans themselves (only for the 2k2-3k versions).

All the models are equipped with backfeed relays and the relative functionality test.

The main features of the PREMIUM PRO series include:

- VFI (On-line) / pure sinusoidal waveform during battery-powered functionality
- Output frequency with automatic selection (auto-sensing)
- Front/rear ventilation
- LCD display
- UPS with configurable and customizable functions (i.e. by-pass thresholds, automatic testing, acoustic alarm, etc.) through proprietary configuration software
- Protected battery expansion connector
- Unlimited expandability of autonomy with dedicated or custom Battery Boxes
- Expansion slot for communication cards (i.e. second USB and RS 232 Port, SNMP, ModBus, etc.)
- RS 232 and USB communication ports
- Frequency converter mode with a derating of 30%
- “Free Running” mode with a derating of 30%
- Eco mode function with 98% yield

STANDARD VERSIONS

- 1000VA - 900W – PF0.9 – 3 batteries, 12V, 7Ah – Small cabinet – with battery expansion
- 1500VA – 1350W – PF 0.9 – 3 batteries, 12V, 9Ah – Small cabinet
- 2200VA – 1980W – PF 0.9 – 6 batteries, 12V, 7Ah – Large cabinet - with battery expansion
- 3000VA – 2700W – PF 0.9 – 6 batteries, 12V, 9Ah – Large cabinet - with battery expansion

ER VERSIONS FOR EXTENDED AUTONOMY

- 2200VA ER, 3000VA ER
- Same features as the standard version

X05 BATTERY BOX

The X05 BATTERY BOX is an accessory which is dedicated to this series of UPS units, or rather has the same dimensions (2U) and aesthetic design.

It is available in two versions (short and long) to be perfectly matched with the various UPS power ratings. There are no internal battery trays: in this case, the hot swap functionality is intended for the entire Battery Box. The short version can be equipped with 3 or 3+3 (in parallel) 7 or 9 Ah batteries and can only be used in conjunction with the 1000VA unit.

The long version can be equipped with 6 or 6+6 (in parallel) 7 or 9 Ah batteries and can be used in conjunction with the 2200VA and 3000VA units.

*Short Battery Box
(USBB36A3A, USBB36M1A)*

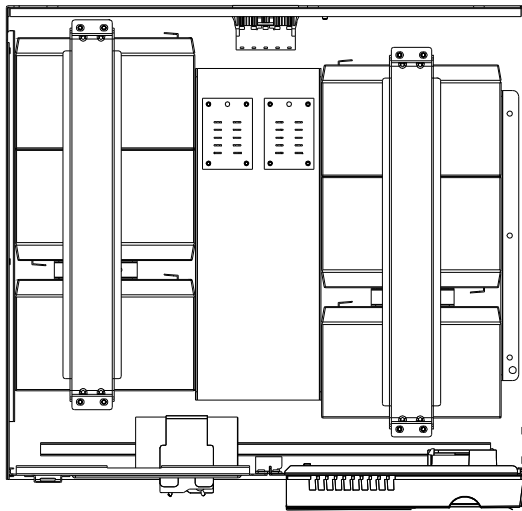

*Long Battery Box
(USBB72A3A, USBB72M1A)*

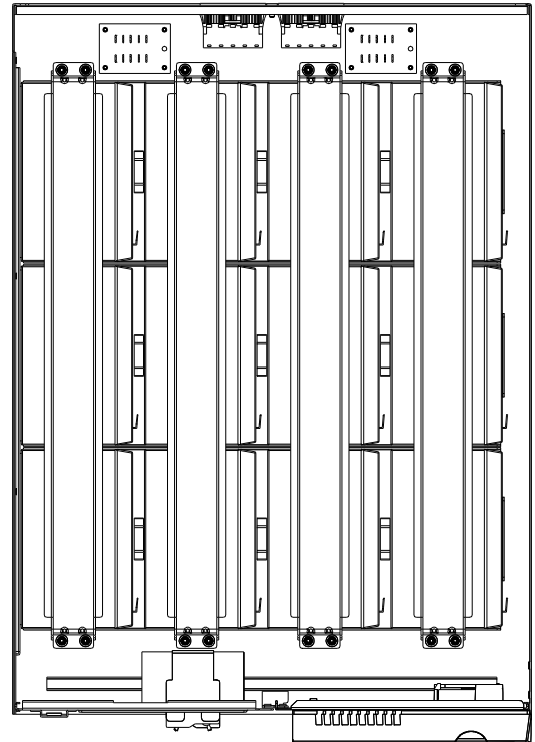

APPEARANCE AND ACCESSORIES

Appearance

page
6



Chassis reference colour: Pantone Black 6U
Colour of the silver parts: RAL 9006

DISPLAY

The diagram below illustrates the layout of the display. It includes the Energy Share socket icon and the possibility of selecting additional operating modes, indicated with MODE1...MODE8.

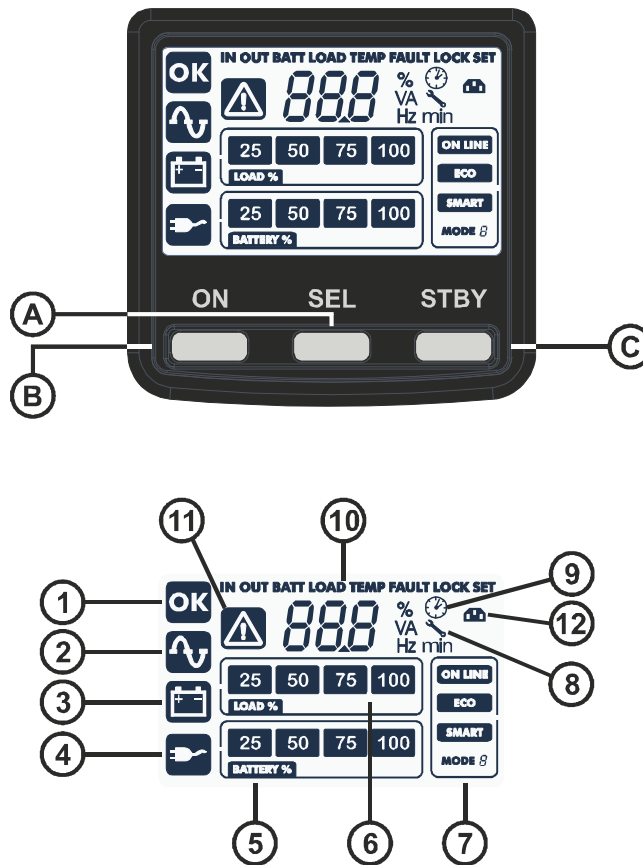

- | | |
|--------------------------|----------------------------------|
| Ⓐ "SEL" Button | Ⓔ Charge level indicator |
| Ⓑ "ON" Button | Ⓕ Configuration area |
| Ⓒ "STAND-BY" Button | Ⓖ Maintenance required indicator |
| ① Regular operating mode | ⑨ Timer indicator |
| ② Network operating mode | ⑩ Measurement display area |
| ③ Battery operating mode | ⑪ Stand-by / alarm indicator |
| ④ Load powered by bypass | ⑫ Energy Share indicator |
| ⑤ Battery life indicator | |

GENERIC ACCESSORIES

MULTIPASS

The UPS unit is compatible with the manual and automatic "MULTIPASS" external bypass, which even allows for hot swapping to be performed for the entire UPS unit.

page

8

OPTIONAL SLOT CARDS

The slot complies with our normal company standard and can therefore accept any of the accessory cards which are currently available for the other series, such as the various MultiCOM cards and the Netman card.

FRONTAL VIEW

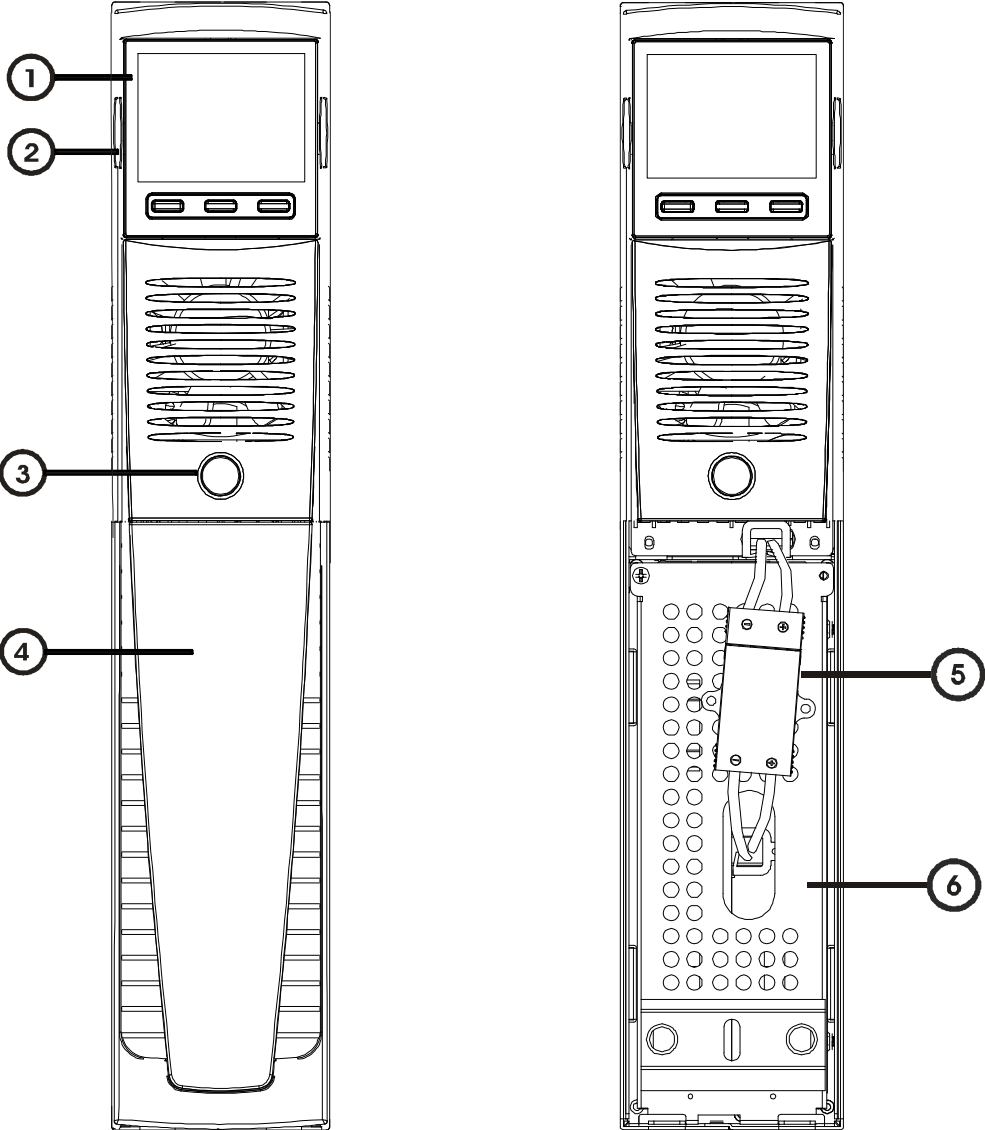

- ① Extractible/rotating display mask
- ② Release slits
- ③ 1/0 Switch

- ④ Removable front panel
- ⑤ Battery pack connector
- ⑥ Battery pack retention panel

REAR VIEWS

The rear portions of the 2200 and 3000VA versions are illustrated below:

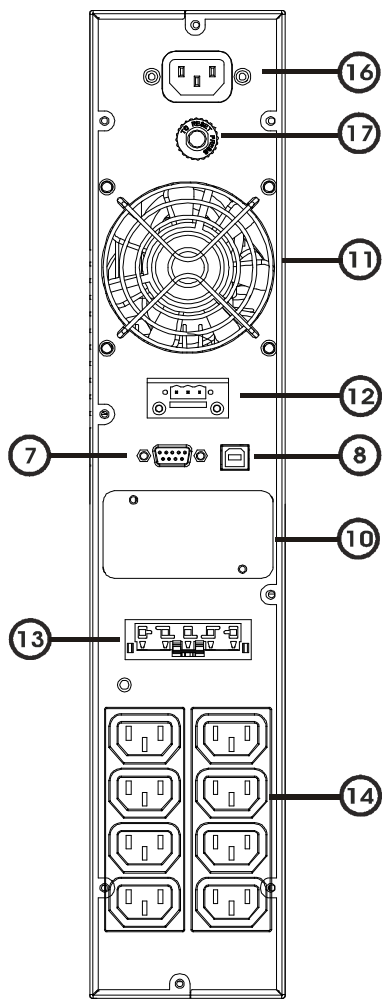

1000VA / 1500VA Model

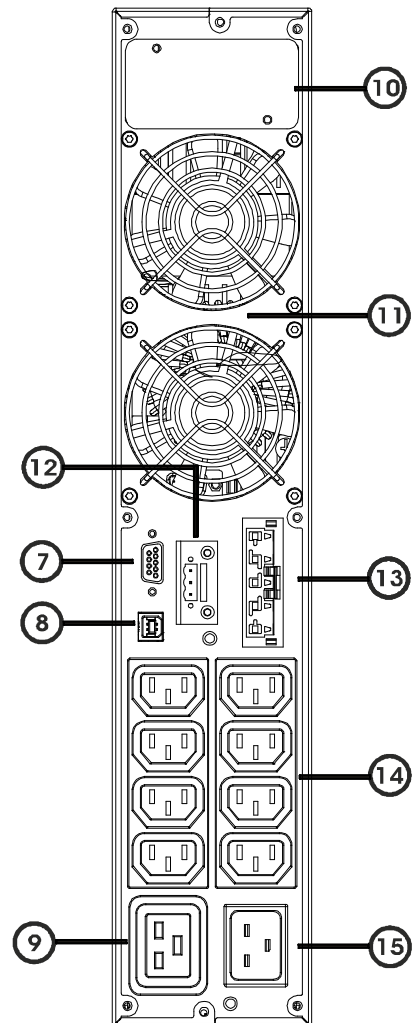

2200VA / 3000VA Model

- | | | | |
|-----------|-------------------------------|-----------|--|
| 7 | RS 232 Communication port | 13 | Battery expansion connector (optional) |
| 8 | USB Communication port | 14 | IEC 10A output socket |
| 9 | IEC 16A output socket | 15 | IEC 16A input plug |
| 10 | Slot for communication cards | 16 | IEC 10A input plug |
| 11 | Cooling fan | 17 | Circuit breaker |
| 12 | Remote control terminal board | | |

Every Battery Box comes supplied with a wiring set and 2 expansion connectors for connection to the UPS unit or to a chain of Battery Boxes.

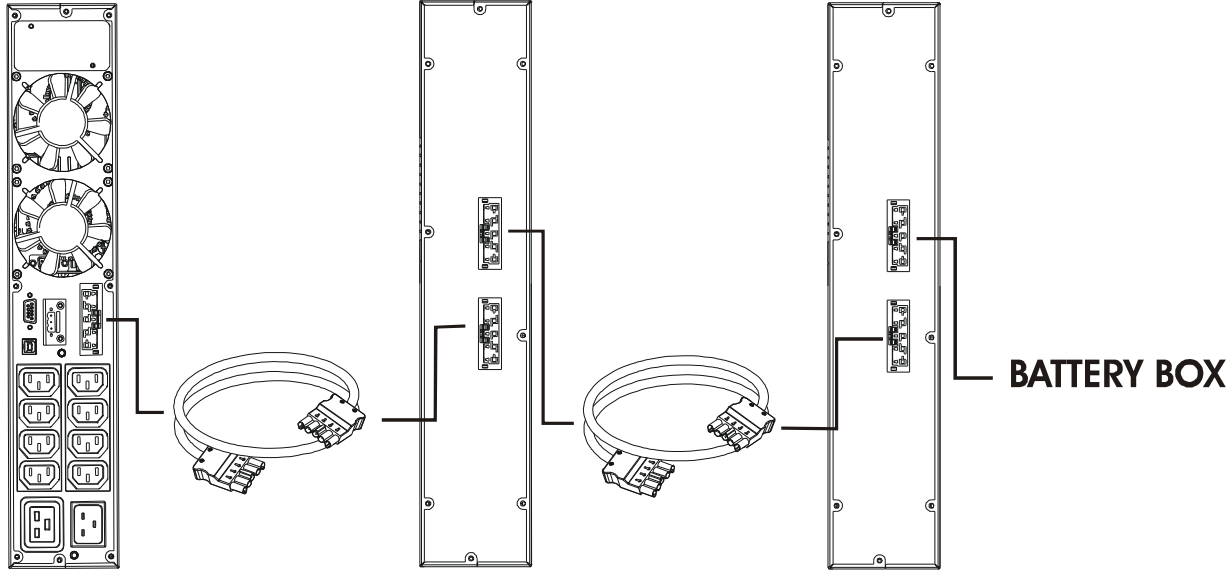

CERTIFICATIONS

The UPS unit is certified according to EMI/EMC EN62040-2 compatibility class C1 for emissions and class 2 for immunity.

The product is classified VFI-SS-111

TECHNICAL DATA TABLE

| UPS MODELS | USPRD100 | USPRD150 | USPRD 2200 / USPRD 220ER | USPRD300 / USPRD 300ER |
|------------|----------|----------|--------------------------------|------------------------------|
|------------|----------|----------|--------------------------------|------------------------------|

INPUT

| | | | | | |
|---|------------------------|---|---|-------------|---------|
| Rated voltage | [Vac] | 220 - 230 - 240 | | | |
| Maximum operating voltage | [Vac] | 300 | | | |
| Voltage range and frequency for no battery intervention | [Vac] [Vac] [Hz] | Maximum: 276 Minimum: 184 ÷ 140 (from 100% to 50% load in linear mode) Return to network powered functionality: 190 Frequency: 40 ÷ 72 | | | |
| Rated frequency | [Hz] | 50 - 60 | | | |
| Rated current (1) | [A] | 5 | 7 | 10.5 / 11.5 | 14 / 15 |
| Power factor @ rated load and voltages | | ≥ 0.99 | | | |
| Current distortion @ rated load and voltages | | 6% | | 10% | |

BYPASS

| | | | | | |
|---|--------|---|--|--|--|
| Accepted voltage range for switching | [Vac] | Minimum configurable threshold: <u>180</u> ÷ 200 Maximum configurable threshold: <u>250</u> ÷ <u>264</u> | | | |
| Accepted frequency range for inverter synchronization | | Selectable: 3% ÷ 10% Default: ±5 % | | | |
| Switching time | [msec] | Typical: 4 | | | |

BATTERY

| | | | | | |
|---|------------|---|----------------|-----------|-----------|
| Number of batteries / V | [n°]x[V] | 3x12V | 3x12V | 6x12V / 0 | 6x12V / 0 |
| Standard capacity | [Ah] | 7Ah | 9Ah | 7Ah | 9Ah |
| Charging current | [A] | 0.7÷0.8A @ UPS on with maximum fan speed About 1A with UPS in Stand-By | | | |
| Charging time (c) | [h] [h] | < 4h for 80% of the load < 4-6h for 90% of the load | | | |
| Expandability and rated voltage of the Battery Box | | 36Vdc | Not expandable | 72Vdc | 72Vdc |
| Charging current (only for ER versions) | | N/A | N/A | 6A | 6A |
| Minimum Battery Box capacity (only for ER versions) | | N/A | N/A | > 40Ah | > 40Ah |

OUTPUT

| | | | | | |
|--------------------------------------|-------|---|------|-------------|-----------|
| Rated voltage | [Vac] | Selectable: 220 / 230 / 240 ±1% | | | |
| Frequency (2) | [Hz] | Selectable: 50, 60 or automatic detection | | | |
| Rated power | [kVA] | 1 | 1.5 | 2.2 | 3 |
| Rated power (3) | [kW] | 0.9 | 1.35 | 1.98 / 1.76 | 2.7 / 2.4 |
| Overload: 100% < load < 110% | | Bypass line available: activates the bypass after 2 sec. shutdown after 120 sec. Bypass line unavailable: shutdown after 60 sec. | | | |
| Overload: 110% < load < 150% | | Bypass line available: activates the bypass after 2 sec. shut down after 4 sec. Bypass line unavailable: shutdown after 4 sec. | | | |
| Load overload > 150% | | Bypass line available: activates the bypass instantaneously shutdown after 1 sec. Bypass line unavailable: shutdown after 0.5 sec. | | | |
| Voltage distortion @ linear load | | ≤ 2% | | | |
| Voltage distortion @ distorting load | | ≤ 4% | | ≤ 3.5% | |
| Current crest factor | | ≥ 3 : 1 | | | |

MISCELLANEOUS

| | | | | |
|--------------------------------|-------|-------|-------|--------|
| Leakage current to ground [mA] | < 2 | | | |
| AC/AC yield @ load=100%Res | 89% | 90.5% | 91.7% | 92.65% |
| AC/AC yield @ load=100%Dist | 87.6% | 89.5% | 92.5% | 92.37% |
| ECO mode yield @ rated load | 97.3% | 98% | 98% | 98% |

| | | | | | |
|---|---|------------------|-------------------|-------------------|-------------------|
| Automatic consumption in ECO mode (batteries disconnected) | 19W | 17.1W | 24.3 | 28W | |
| DC/AC yield in BATTERY mode | 85.0% | 86.2% | 86.4% | 86.6% | |
| Automatic consumption from the network (batteries disconnected) | 49.2W | 48.6W | 59.3W | 5850.5W | |
| Automatic consumption in Stand-by mode (batteries disconnected) | 15.7W | 14.7W | 15.1W | 18W | |
| Automatic consumption with on/off switch turned off | 0.5W | 0.5W | 0.5W | 0.33W | |
| Power loss with resistive nominal load | [W] [BTU/h] [kcal/h] | 100 335 85 | 130 445 112 | 164 560 141 | 200 670 170 |
| Operating room temperature (6) [°C] | 0 – 40 | | | | |
| Humidity | < 90% without condensation | | | | |
| Installation height | Operation: 1000 m at nominal power (-1% power for every 100 m above 1000 m) 4000 m maximum Transport: <15000 m | | | | |
| Protection devices | excessive battery discharge – overcurrent – short circuit – over voltage – undervoltage – thermal | | | | |
| Overvoltage protection | 2 VDR x 300 Joules | | | | |
| Noise levels | < 40 dB(A) at 1 m | | | | |
| Room temperature (4) [°C] | 0 – 40 | | | | |
| Humidity | < 90% without condensation | | | | |
| Protection devices | excessive battery discharge - overcurrent - short circuit - over voltage - undervoltage - thermal | | | | |
| Dimensions L x D x H (5) [mm] | 87 x 425 x 450 | | 87 x 625 x 450 | | |
| Net weight [Kg] | 17 | 18 | 29.5 / 14.5 | 31.5 / 15 | |
| Gross weight [Kg] | 20.5 | 21.5 | 33.5 / 18.5 | 36 / 19 | |

(1) @ rated load, rated voltage of 220 Vac, battery charging

(2) *Automatic detection*: If the network frequency is within $\pm 5\%$ of the selected value, the UPS is synchronized with the network. If the frequency is off tolerance or battery-powered functionality is enabled, the frequency is that which is selected $\pm 0.1\%$. *Power derating*: The UPS unit derates the output power to 70% of the rated power if the UPS is operating as a frequency converter. This means that it is configured so the output is not synchronised with the input (without link) or else is configured with an option other than automatic detection.

(3) The UPS unit derates the active output power from PF=0.9 to PF=0.8 if a battery box is used for extended autonomy.

(4) 20-25 °C for increased battery life.

(5) The dimensions shown in the table refer to the tower version, taking the support feet into account. The rack version is suitable for being housed in a 19" cabinet with an encumbrance of 2U.

| BATTERY BOX MODELS | | USBB36A3A | USBB36M1A | USBB72A3A | USBB72M1A |
|-----------------------|-------|----------------|-----------|----------------|-----------|
| Rated battery voltage | [Vdc] | 36Vdc | | 72Vdc | |
| Dimensions L x D x H | [mm] | 87 x 425 x 450 | | 87 x 625 x 450 | |
| Net weight | [Kg] | 13.5 | 20.5 | 25 | 38 |
| Gross weight | [Kg] | 16.5 | 23.5 | 29 | 42 |

In the event that the UPS unit is connected to a Battery Box, the maximum active power will be derated from PF 0.9 to PF 0.8.

COMMUNICATION PORTS AND FIRMWARE

The UPS comes with a standard RS 232 port with input and output signals, a USB Port and an expansion slot for connecting additional electronic boards.

RS 232 CONNECTOR

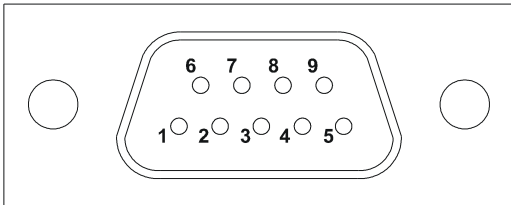
| RS 232 CONNECTOR | | |
|--|---|---|
|  | | |
| PIN # | SIGNAL | NOTES |
| 1 | Programmable output *: [default: UPS shut down] | (*) Opto-isolated contact max. +30Vdc / 35mA. These contacts can be associated with other events using the appropriate software (**) Opto-isolated control +5÷15Vdc. These contacts can be associated with other events using the appropriate software For additional information about interfacing with the UPS unit, please refer to the appropriate manual |
| 2 | TXD | |
| 3 | RXD | |
| 4 | Programmable input **: [default: disabled] | |
| 5 | GND | |
| 6 | DC Power Supply (Imax = 20mA) | |
| 7 | Programmable input **: [default: disabled] | |
| 8 | Programmable output *: [default: discharge pre-alarm] | |
| 9 | Programmable output *: [default: battery-powered functionality] | |

COMMUNICATION SLOT

The UPS comes supplied with an expansion slot for optional communication cards (see the diagram on the right), which can allow the device to communicate using the most common communication standards.

Some examples include:

- Additional RS 232 and USB communication ports
- Serial duplicator
- Ethernet network card with TCP/IP, HTTP and SNMP protocols
- JBUS / MODBUS protocol converter card
- PROFIBUS protocol converter card
- Card with isolated relay contacts

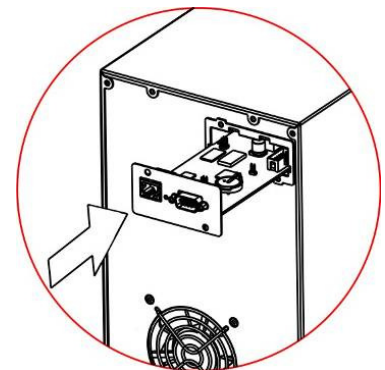

Please consult the website www.schrack.com to check the availability of additional accessories

Connections for REPO and remote ON/OFF functionality

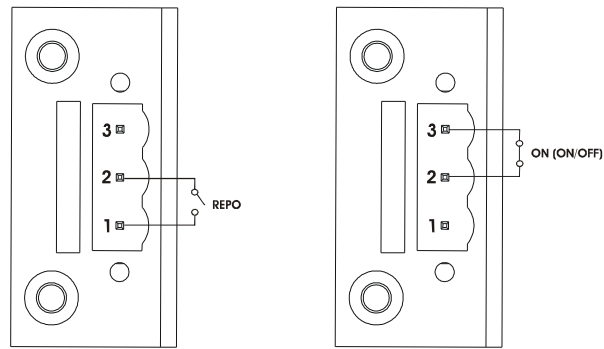

TECHNICAL DATA FOR “PIN 6” POWER THROUGH THE RS 232 PORT

The voltage provided by the serial port's pin 6 power depends on the absorbed current.

$V_{CC_{max}}$: 10.8Vdc without load

$V_{CC_{min}}$: 8Vdc @ 25mA

Firmware

The firmware of the UPS unit can be updated by inserting the appropriate programming card into the expansion Slot.

THE COMPANY

HEADQUARTERS

SCHRACK TECHNIK GMBH
Seybelgasse 13, 1230 Wien
TEL +43(0)1/866 85-0
FAX +43(0)1/866 85-1560
E-MAIL info@schrack.com



AUSTRIAN QUARTERS

CARINTHIA
Ledererstraße 3
9020 Klagenfurt
TEL +43(0)463/333 40-0
FAX +43(0)463/333 40-15
E-MAIL klagenfurt@schrack.com



UPPER AUSTRIA
Franzosenhausweg 51b
4030 Linz
TEL +43(0)732/376 699-0
FAX +43(0)732/376 699-20
E-MAIL linz@schrack.com



SALZBURG
Bachstraße 59-61
5023 Salzburg
TEL +43(0)662/650 640-0
FAX +43(0)662/650 640-26
E-MAIL salzburg@schrack.com



SCHRACK COMPANIES

BELGIUM
SCHRACK TECHNIK B.V.B.A.
Twaalfapostelenstraat 14
BE-9051 St-Denijs-Westrem
TEL +32 9/384 79 92
FAX +32 9/384 87 69
E-MAIL info@schrack.be



CROATIA
SCHRACK TECHNIK D.O.O.
Zavrtnica 17
HR-10000 Zagreb
TEL +385 1/605 55 00
FAX +385 1/605 55 66
E-MAIL schrack@schrack.hr



POLAND
SCHRACK TECHNIK
POLSKA SP.Z.O.O.
ul. Annopol 3
PL-03-236 Warszawa
TEL +48 22/331 48 31
FAX +48 22/331 48 33
E-MAIL se@schrack.pl



STYRIA, BURGENLAND
Kärntnerstraße 341
8054 Graz
TEL +43(0)316/283 434-0
FAX +43(0)316/283 434-64
E-MAIL graz@schrack.com

TYROL
Richard Bergerstraße 12
6020 Innsbruck
TEL +43(0)512/392 580-0
FAX +43(0)512/392 580-30
E-MAIL innsbruck@schrack.com

VORARLBERG
Wallenmahd 23
6850 Dornbirn
TEL +43(0)5572/238 33-0
FAX +43(0)5572/238 33-14
E-MAIL dornbirn@schrack.com

**VIENNA, LOWER AUSTRIA,
BURGENLAND**
Seybelgasse 13
1230 Wien
TEL +43(0)1/866 85-500
FAX +43(0)1/866 85-441
E-MAIL wien@schrack.com

NETZWERKTECHNIK
Seybelgasse 13, 1230 Wien
TEL +43(0)1/866 85-180
FAX +43(0)1/866 85-136
E-MAIL netzwerktechnik@schrack.com

LICHTTECHNIK
Seybelgasse 13, 1230 Wien
TEL +43(0)1/866 85-543
FAX +43(0)1/866 85-561
E-MAIL lichttechnik@schrack.com

ROMANIA
SCHRACK TECHNIK SRL
Str. Simion Barnutiu nr. 15
RO-3700 Oradea
TEL +40 259/435 887
FAX +40 259/412 892
E-MAIL schrack@schrack.ro

SERBIA
SCHRACK TECHNIK D.O.O.
Kumodraska 260
YU-11000 Beograd
TEL +38 1/11 309 2600
FAX +38 1/11 309 2620
E-MAIL office@schrack.co.yu

SLOVAC REPUBLIC
SCHRACK TECHNIK SPOL. SR.O.
Langsfeldova 2
SK-03601 Martin
TEL +42 1/43 422 16 41
FAX +42 1/43 423 95 56
E-MAIL martin@schrack.sk

SLOVENIA
SCHRACK TECHNIK D.O.O.
Glavni trg 47
SLO-2380 Slovenj Gradec
TEL +38 6/2 883 92 00
FAX +38 6/2 884 34 71
E-MAIL schrack.sg@schrack.si

CZECH REPUBLIC
SCHRACK TECHNIK SPOL. SR.O.
Dolnomecholupska 2
CZ-10200 Praha 10 – Hostivar
TEL +42(0)2/810 08 264
FAX +42(0)2/810 08 462
E-MAIL praha@schrack.cz

HUNGARY
SCHRACK TECHNIK KFT.
Vidor u.
H-1172 Budapest
TEL +36 1/253 14 01
FAX +36 1/253 14 91
E-MAIL schrack@schrack.hu