



I-ON

technical and dimensional information

I.ON AUTOSTART - TECHNICAL CHARACTERISTICS

CODE	GWJ 1001 A	GWJ 1002 A	GWJ 1003 A
Charging mode (EN 61851)	Mode 3	Mode 3	Mode 3
Charging socket (EN 62196)	2 x Type 2	2 x Type 2	2 x Type 2
Connector type	Socket (IPxxD)	Socket (IPxxD)	Socket (IPxxD)
Input			
Power supply (in-out)	3 x 35 mm ²	5 x 16 mm ²	5 x 35 mm ²
Rated current	64A	32A	64A
Total power	14.8 kW	22 kW	44 kW
Output			
Voltage	230V	400V	400V
Maximum current	32A + 32A	16A + 16A	32A + 32A
Maximum power	7.4 kW + 7.4 kW	11 kW + 11 kW	22 kW + 22 kW
Thermal magnetic circuit	40A - 2P - D Curve	20A - 4P - D Curve	40A - 4P - D Curve
RCCB protection	40A - 2P - Type B	20A - 4P - Type B	40A - 4P - Type B
Energy metering	-	-	-
Charging activation	FREE	FREE	FREE
Human interface	TFT Display	TFT Display	TFT Display
MECHANICAL CHARACTERISTICS (valid for all codes)			
Installation type	Floor-mounted (fixing base already included)		
Material	Steel sheet		
Exterior Colour	Grey Chassie, Cap RAL7011		
Surface treatment	anti-graffiti and anti-corrosion surface painting		
IP protection	IP55		
Impact protection	IK10		
Operating temperature	-25°C / +50°C		
ACCESSORIES (valid for all codes)			
Floor mounting plate	GWJ 8021		

I.ON AUTOSTART - DIMENSIONAL TABLES

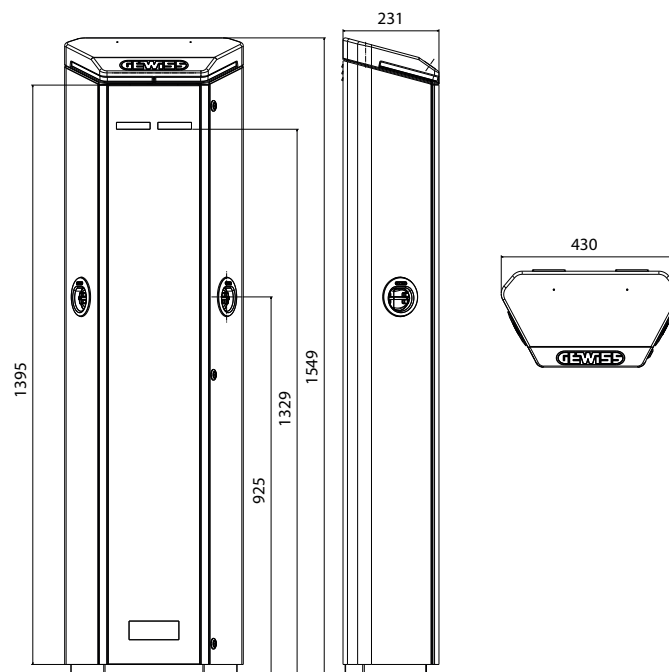

I.ON RFID - TECHNICAL CHARACTERISTICS

CODE	GWJ 1001 R GWJ 1021 R*	GWJ 1002 R	GWJ 1003 R GWJ 1023 R*
Charging mode(EN 61851)	Mode 3	Mode 3	Mode 3
Charging socket (EN 62196)	2 x Type 2	2 x Type 2	2 x Type 2
Connector type	Socket (IPxxD)	Socket (IPxxD)	Socket (IPxxD)
Input			
Power supply (in-out)	3 x 35 mm ²	5 x 16 mm ²	5 x 35 mm ²
Rated current	64A	32A	64A
Total power	14.8 kW	22 kW	44 kW
Output			
Voltage	230V	400V	400V
Maximum current	32A + 32A	16A + 16A	32A + 32A
Maximum power	7.4 kW + 7.4 kW	11 kW + 11 kW	22 kW + 22 kW
Magnetothermic protection	40A - 2P - D Curve	20A - 4P - D Curve	40A - 4P - D Curve
RCCB protection	40A - 2P - Type B	20A - 4P - Type B	40A - 4P - Type B
Energy metering	YES, MID Type	YES, MID Type	YES, MID Type
Charging activation	RFID	RFID	RFID
Human interface	TFT Display	TFT Display	TFT Display
MECHANICAL CHARACTERISTICS (valid for all codes)			
Installation type	Floor-mounted (fixing base already included)		
Material	Steel sheet		
Exterior Colour	Grey Chassie, Cap RAL7011		
Surface treatment	anti-graffiti and anti-corrosion surface painting		
IP protection	IP55		
Impact protection	IK10		
Operating temperature	-25°C / +50°C		
ACCESSORIES (valid for all codes)			
Floor mounting plate	GWJ 8021		
RFID card	GWJ 8001		
ethernet	GWJ 8011		
Ethernet + 4g modem + antenna kit	GWJ 8012		

(*) GWJ1021R and GWJ1023R are equipped with "user 1" (socket Type2 + Type F socket) and "user 2" (socket type2 + Type F socket). Each "user" can activate only 1 socket at the same time.

I.ON RFID - DIMENSIONAL TABLES

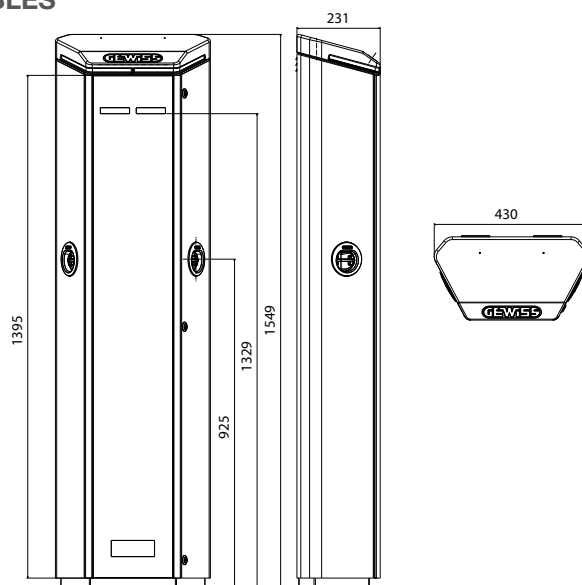



I-ON

technical and dimensional information

I.ON CLOUD - TECHNICAL CHARACTERISTICS

CODE	GWJ 1001 W GWJ 1001 L GWJ 1021 W*	GWJ 1002 W GWJ 1002 L	GWJ 1003 W GWJ 1003 L GWJ 1023 W*
Charging mode (EN 61851)	Mode 3	Mode 3	Mode 3
Charging socket (EN 62196)	2 x Type 2 IPXXD	2 x Type 2 IPXXD	2 x Type 2 IPXXD
Connector type	Socket (IPxxD)	Socket (IPxxD)	Socket (IPxxD)
Input			
Power supply (in-out)	3 x 35 mm ²	5 x 16 mm ²	5 x 35 mm ²
Rated current	64A	32A	64A
Total power	14.8 kW	22 kW	44 kW
Output			
Voltage	230V	400V	400V
Maximum current	32A + 32A	16A + 16A	32A + 32A
Maximum power	7.4 kW + 7.4 kW	11 kW + 11 kW	22 kW + 22 kW
Magnetothermic protection	40A - 2P - D Curve	20A - 4P - D Curve	40A - 4P - D Curve
RCCB protection	40A - 2P - Type B	20A - 4P - Type B	40A - 4P - Type B
Energy metering	YES, MID Type	YES, MID Type	YES, MID Type
Connectivity	OCPP 1.6 J	OCPP 1.6 J	OCPP 1.6 J
Charging activation	RFID or APP	RFID or APP	RFID or APP
Human interface	TFT Display	TFT Display	TFT Display
MECHANICAL CHARACTERISTICS (valid for all codes)			
Installation type	Floor-mounted (fixing base already included)		
Material	Steel sheet		
Exterior Colour	Grey Chassie, Cap RAL7011		
Surface treatment	anti-graffiti and anti-corrosion surface painting		
IP protection	IP55		
Impact protection	IK10		
Operating temperature	-25°C / +50°C		
ACCESSORIES (valid for all codes)			
Floor mounting plate	GWJ 8021		
RFID card	GWJ 8001		
Load management kit for public environment	GWJ 8031		

NOTE: 4G Router available in the codes with final termination "W".

(*) GWJ1021W and GWJ1023W are equipped with "user 1" (socket Type2 + Type F socket) and "user 2" (socket type2 + Type F socket). Each "user" can activate only 1 socket at the same time.

I.ON CLOUD - DIMENSIONAL TABLES

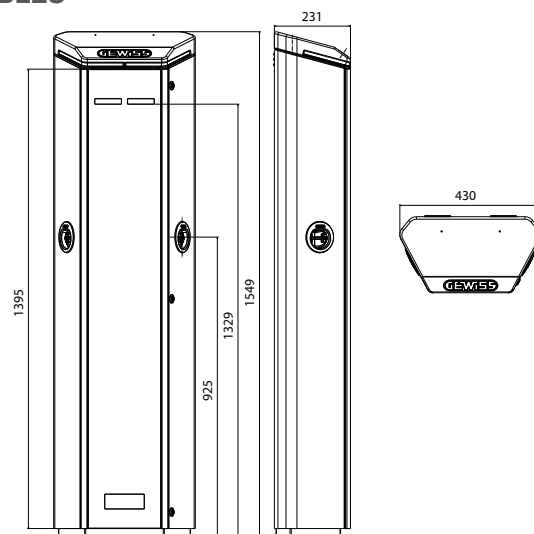

I-ON WALL

I.ON WALL AUTOSTART - TECHNICAL CHARACTERISTICS

CODE	GWJ 2101 A	GWJ 2102 A	GWJ 2103 A
Charging mode (EN 61851)	Mode 3	Mode 3	Mode 3
Charging socket (EN 62196)	2 x Type 2	2 x Type 2	2 x Type 2
Connector type	Socket (IPxxD)	Socket (IPxxD)	Socket (IPxxD)
Input			
Power supply (2 separate lines)	2 x (3 x 10 mm ²)	2 x (5 x 10 mm ²)	2 x (5 x 10 mm ²)
Rated current	64A	32A	64A
Total power	14.8 kW	22 kW	44 kW
Output			
Voltage	230V	400V	400V
Maximum current	32A + 32A	16A + 16A	32A + 32A
Maximum power	7.4 kW + 7.4 kW	11 kW + 11 kW	22 kW + 22 kW
Magnetohermic protection	-	-	-
RCCB protection	-	-	-
Energy metering	-	-	-
Charging activation	FREE	FREE	FREE
Human interface	TFT Display	TFT Display	TFT Display
MECHANICAL CHARACTERISTICS (valid for all codes)			
Installation type	Wall or Support mounting		
Material	Steel sheet		
Exterior Colour	Grey Chassie, Cap RAL7011		
Surface treatment	anti-graffiti and anti-corrosion surface painting		
IP protection	IP55		
Impact protection	IK10		
Operating temperature	-25°C / +50°C		
ACCESSORIES (valid for all codes)			
Pole support kit	GW46551		

I.ON WALL AUTOSTART - DIMENSIONAL TABLES

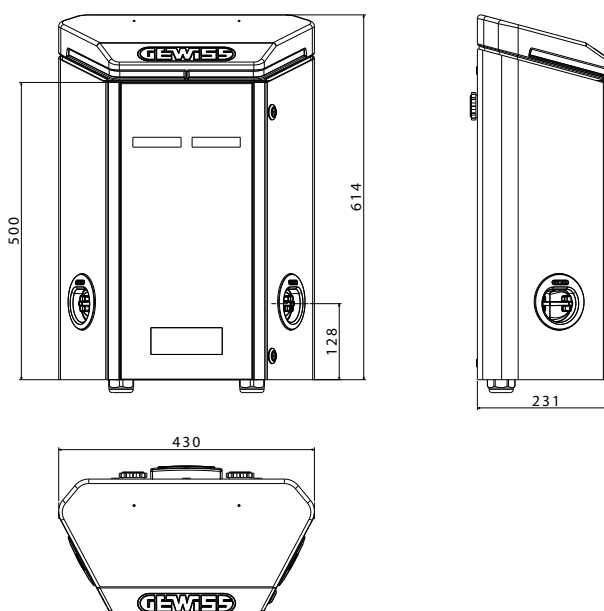



I-ON

technical and dimensional information

I.ON WALL RFID - TECHNICAL CHARACTERISTICS

CODE	GWJ 2101 R GWJ 2121 R*	GWJ 2102 R	GWJ 2103 R GWJ 2123 R*
Charging mode (EN 61851)	Mode 3	Mode 3	Mode 3
Charging socket (EN 62196)	2 x Type 2 *	2 x Type 2	2 x Type 2 *
Connector type	Socket (IPxxD)	Socket (IPxxD)	Socket (IPxxD)
Input			
Power supply (2 separate lines)	2 x (3 x 10 mm ²)	2 x (5 x 10 mm ²)	2 x (5 x 10 mm ²)
Rated current	64A	32A	64A
Total power	14.8 kW	22 kW	44 kW
Output			
Voltage	230V	400V	400V
Maximum current	32A + 32A	16A + 16A	32A + 32A
Maximum power	7.4 kW + 7.4 kW	11 kW + 11 kW	22 kW + 22 kW
Magnetothermic protection	-	-	-
RCCB protection	-	-	-
Energy metering	YES, MID Type	YES, MID Type	YES, MID Type
Charging activation	RFID	RFID	RFID
Human interface	TFT Display	TFT Display	TFT Display
MECHANICAL CHARACTERISTICS (valid for all codes)			
Installation type	Wall or Support mounting		
Material	Steel sheet		
Exterior Colour	Grey Chassie, Cap RAL7011		
Surface treatment	anti-graffiti and anti-corrosion surface painting		
IP protection	IP55		
Impact protection	IK10		
Operating temperature	-25°C / +50°C		
ACCESSORIES (valid for all codes)			
Pole support kit	GW 46551		
RFID card	GWJ 8001		
ethernet	GWJ 8011		
Ethernet + 4g modem + antenna kit	GWJ 8012		

(* GWJ2121R and GWJ2123R are equipped with "user 1" (socket Type2) and "user 2" (Type F socket).

I.ON WALL RFID - DIMENSIONAL TABLES

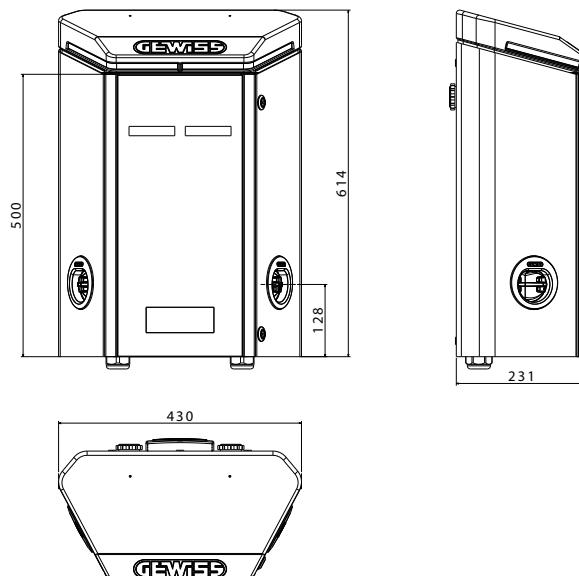

I.ON WALL CLOUD - TECHNICAL CHARACTERISTICS

CODE	GWJ 2101 W GWJ 2101 L GWJ 2121 W*	GWJ 2102 W GWJ 2102 L	GWJ 2103 W GWJ 2103 L GWJ 2123 W*
Charging mode (EN 61851)	Mode 3	Mode 3	Mode 3
Charging socket (EN 62196)	2 x Type 2 IPXXD *	2 x Type 2 IPXXD	2 x Type 2 IPXXD *
Connector type	Socket (IPxxD)	Socket (IPxxD)	Socket (IPxxD)
Input			
Power supply (2 separate lines)	2 x (3 x 10 mm ²)	2 x (5 x 10 mm ²)	2 x (5 x 10 mm ²)
Rated current	64A	32A	64A
Total power	14.8 kW	22 kW	44 kW
Output			
Voltage	230V	400V	400V
Maximum current	32A + 32A	16A + 16A	32A + 32A
Maximum power	7.4 kW + 7.4 kW	11 kW + 11 kW	22 kW + 22 kW
Magnetohermic protection	-	-	-
RCCB protection	-	-	-
Energy metering	YES, MID Type	YES, MID Type	YES, MID Type
Connectivity	OCPP 1.6 J	OCPP 1.6 J	OCPP 1.6 J
Charging activation	RFID or APP	RFID or APP	RFID or APP
Human interface	TFT Display	TFT Display	TFT Display
MECHANICAL CHARACTERISTICS (valid for all codes)			
Installation type	Wall or Support mounting		
Material	Steel sheet		
Exterior Colour	Grey Chassie, Cap RAL7011		
Surface treatment	anti-graffiti and anti-corrosion surface painting		
IP protection	IP55		
Impact protection	IK10		
Operating temperature	-25°C / +50°C		
ACCESSORIES (valid for all codes)			
Pole support kit	GW 46551		
RFID card	GWJ 8001		
ethernet	GWJ 8011		
Ethernet + 4g modem + antenna kit	GWJ 8012		
Load management kit for public environment	GWJ 8031		

NOTE: 4G Router available in the codes with final termination "W".

(*) GWJ2121W and GWJ2123W are equipped with "user 1" (socket Type2) and "user 2" (Type F socket).

I.ON WALL CLOUD - DIMENSIONAL TABLES

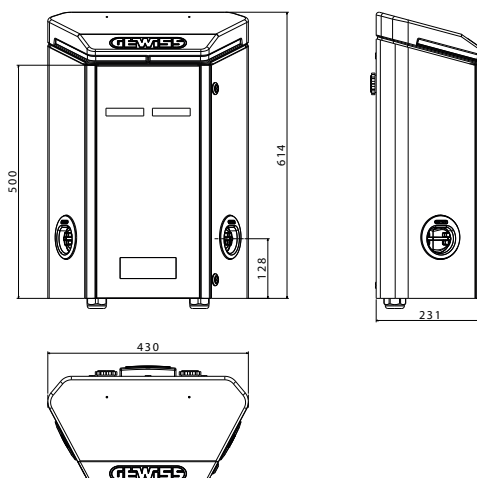



I-ON

backend connection scheme

example 1

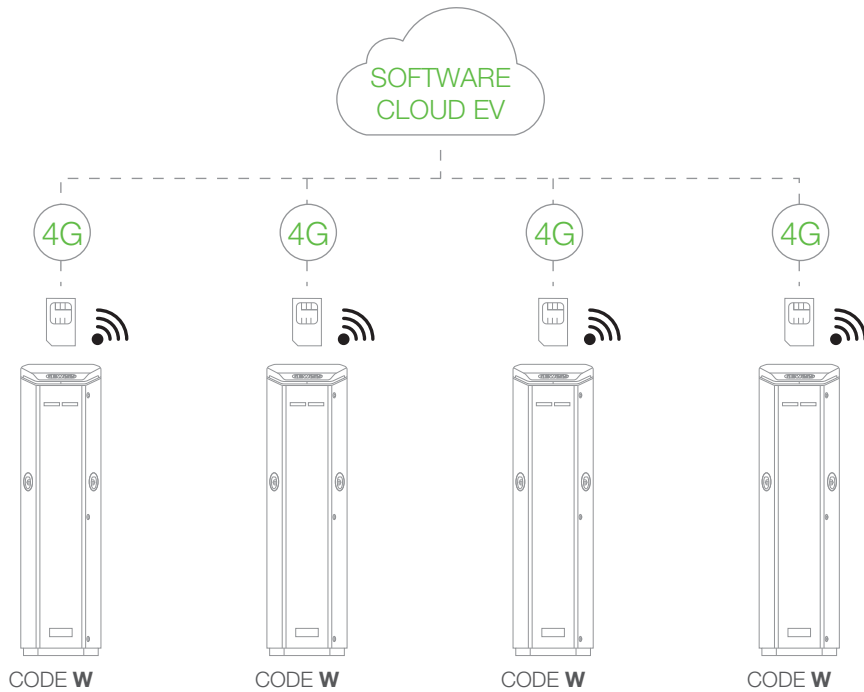

Charging stations are all equipped with Kit Router 4G (version «W») and communicate «Peer To Peer» with the communication backend via OCPP 1.6 JSON protocol.

example 2

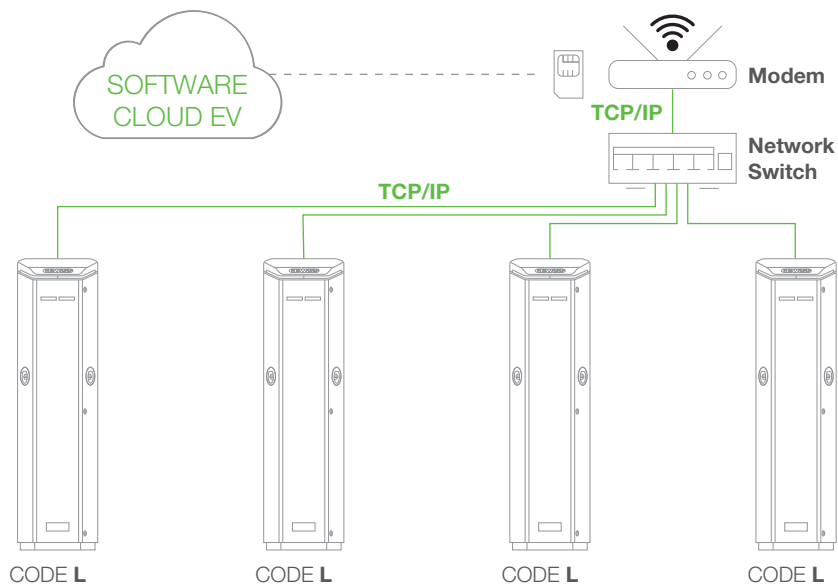

The charging stations are all equipped with Ethernet Kit (version «L»), and are all wired in the centre of the star within a switch. Connectivity takes place through a Router available in the system.

example 3 (Master / Slave)

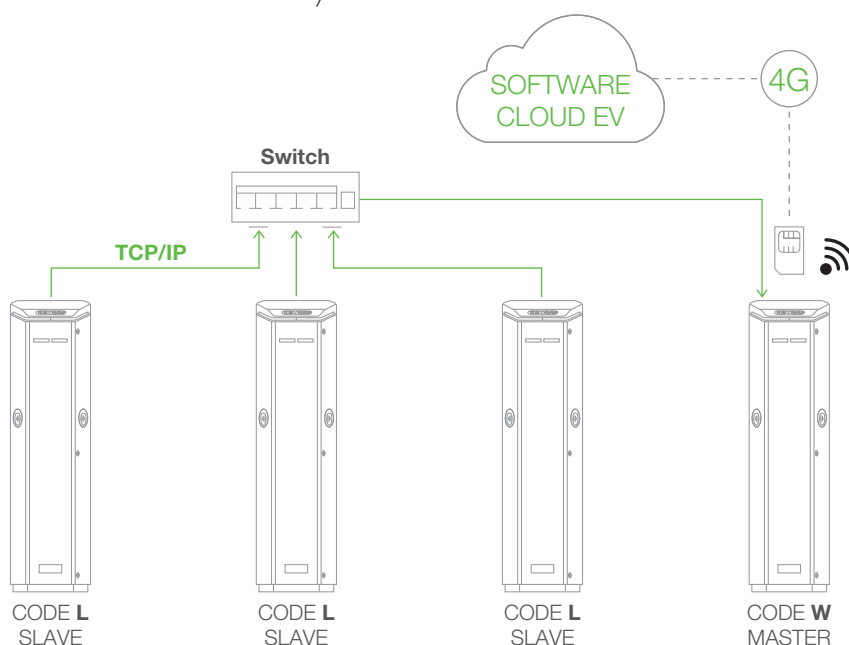

The charging stations are all equipped with Ethernet Kit (version «L») are wired in the center of the star within a Switch. Data is then transferred to THE MASTER station that integrates a Router and the SIM is wired in and out with TCP/IP line and only the last charging station has a 4G SIM that communicates with the backend via OCPP 1.6 JSON protocol.



JoinOn

load management system through site controller

Acquisition of charging power information

To dynamically limit the total power reserved for charging stations, the Site Controller records both the current on each phase of the “charging” station and the total power for each phase of the entire system in real time.

This also offers the possibility to consider other loads that are absorbing energy from the grid, for example: lights, heating, elevators or other.

On the one hand, electrical meters integrated into charging stations are used for a complete recording of measurements for EV charging, and at the same time, an additional electrical meter with TCP/IP capability is used to collect the total currents/powers (including the other loads mentioned above).

Maximum power management

The desired maximum total power is a parameter that can be defined and modified through the load management system from the JoinOn platform. Based on this value and also taking into account the other measured loads, the Site Controller calculates the residual charging power available and dynamically controls (every 30 seconds, adjustable) the charging powers of each individual charging process.

Phased charging balancing

Single-phase charging processes are recognized by the Site Controller and compensated as best as possible by reducing charging processes accordingly.

system layout (site controller)

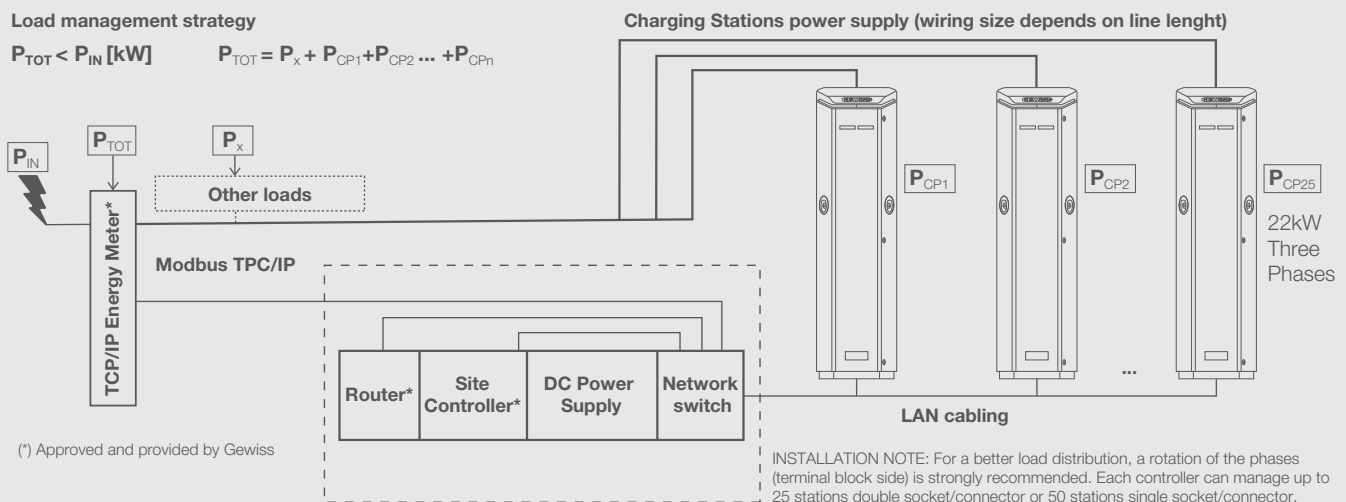

Gewiss site controller applications

With its load management functions, the Site Controller supports all applications for the construction of charging networks in public, semi-public or even private contexts (example: condominiums or Corporate) in order to always meet the required load limits.

Components and technical data

The current load management system is as follows:

- **Site Controller** is the heart of the DLM load management system and allows the simultaneous management of max. 50 charging sockets. Device technical information:
 - - DA-1000 Bay Trail Celeron J1900 Quad Core Platform motherboard.

- - Primary storage 32GB 2.5" SSD.
- - Windows 10 Home operating system - 64-bit.
- - AC Power Adapter DC 12V, 60W - 3-pin Terminal.
- - Memory (RAM) 4 GB SO-DIMM DDR3L 1600.
- - Temperature $-25^{\circ}\text{C} \div 70^{\circ}\text{C}$.
- The **TCP/IP Energy Meter** (it is optional and must be purchased from Gewiss, necessary only when dynamic power management is required also considering the other loads in use on the site: lights, air conditioners, etc.);
- a **Router** (used to set the LAN network between charging stations, the TCP/IP energy meter and set up GSM communication with the JoinOn BackEnd. NOTE: charging stations do not need their own GSM communication, using the Site Controller it will operate as the Master of the system);
- a **12V DC Power Supply** (max 10A);
- a **Switch** for connecting all load management equipment and stations through LAN cables;

For further information, please contact the SAT Technical Support Service.

wiring layout (site controller)

