



VVF43..
VVF43..K



VXF43..

ACVATIX™

2- and 3-port valves with flanged connections, PN 16

VVF43..
VXF43..

From the large-stroke valve line

- High-performance valves for medium temperatures from -20...220 °C
- Valve body of nodular cast iron EN-GJS-400-18-LT or higher
- DN 65...250
- k_{vs} 50...630 m³/h
- Flange type 21, flange design B
- VVF43..K with pressure compensation to handle high differential pressure
- Equipable with electro-motoric actuators SAV.. or electro-hydraulic actuators SKC..

Use

In boiler, district heating and refrigeration plants, cooling towers, heating groups, and in air handling units as control or shutoff valves.

For use in closed or open hydraulic circuits (observe cavitation).

Type summary

	Valves PN 16 	Actuators				SAV.. ³⁾		SKC..	
		Stroke				40 mm			
		Positioning force				1600 N		2800 N	
		Data sheet				N4503		N4566	
		Stock number	DN	k _{vs} [m ³ /h]	S _v	Δp _s	Δp _{max}	Δp _s	Δp _{max}
						[kPa]			
Fluids Preferred flow direction A – AB with fluids for low noise operation and high kvs-values with all actuator types	VVF43.65-50	S55206-V100	65	50	> 100	450	400	700	650
	VVF43.65-63	S55206-V101	65	63					
	VVF43.80-80	S55206-V102	80	80					
	VVF43.80-100	S55206-V103	80	100		250	225	450	400
	VVF43.100-125	S55206-V104	100	125		160	125	300	250
	VVF43.100-160	S55206-V105	100	160		125	90	175	160
	VVF43.125-200	S55206-V106	125	200					
	VVF43.125-250	S55206-V107	125	250					
	VVF43.150-315	S55206-V108	150	315		80	60	125	100
VVF43.150-400	S55206-V109	150	400						
Steam ¹⁾ Exclusive flow direction AB – A for steam. Also useful for maximum close-off pressure Δp _s and maximum differential pressure in operation (Δp _{max}) with fluids. Use with electro- hydraulic actuators only	VVF43.65-50	S55206-V100	65	50	> 100	-	-	1600	800
	VVF43.65-63	S55206-V101	65	63					750
	VVF43.80-80	S55206-V102	80	80					500
	VVF43.80-100	S55206-V103	80	100					300
	VVF43.100-125	S55206-V104	100	125					
	VVF43.100-160 ²⁾	S55206-V105	100	150					200
	VVF43.125-200	S55206-V106	125	200					
	VVF43.125-250 ²⁾	S55206-V107	125	220					
	VVF43.150-315 ²⁾	S55206-V108	150	280					800
	VVF43.150-400 ²⁾	S55206-V109	150	360					
Fluids and Steam Compensated valves above DN 65 are optimized for a single flow direction for fluids and steam DN 65..150: AB – A DN 200/250: A – AB	VVF43.65-63K	S55206-V110	65	63	> 100	-	-	1600	800
	VVF43.80-100K	S55206-V111	80	100					
	VVF43.100-150K	S55206-V120	100	150					
	VVF43.125-220K	S55206-V121	125	220					
	VVF43.150-315K	S55206-V122	150	315					
	VVF43.200-450K	S55206-V123	200	450	>50	-	-	1200	
	VVF43.250-630K	S55206-V124	250	630				1000	

		Stock number	DN	k _{vs} [m ³ /h]	S _v	Δp _{max} [kPa]				
						A → AB B	AB → A B	A → AB B	AB → A B	
Fluids	VXF43.65-50	S55206-V125	65	50	> 100	400	100	650	200	
	VXF43.65-63	S55206-V115	65	63						
	VXF43.80-80	S55206-V126	80	80						
	VXF43.80-100	S55206-V116	80	100		225	50	400	150	
	VXF43.100-125	S55206-V127	100	125		125		250		
	VXF43.100-160	S55206-V117	100	160				90	160	100
	VXF43.125-200	S55206-V128	125	200		60			100	70
	VXF43.125-250	S55206-V118	125	250						
	VXF43.150-315	S55206-V129	150	315		60	100	70		
	VXF43.150-400	S55206-V119	150	400						

¹⁾ Operate with opposite flow direction with steam

²⁾ Reduced k_{vs} value

³⁾ Usable up to a max. medium temperature of 130 °C; SAV.. available in select countries only

DN = Nominal size

k_{vs} = Flow nominal value of cold water (5...30 °C) through the fully opened valve (H₁₀₀) at a differential pressure of 100 kPa (1 bar)

S_v = Rangeability

Δp_s = Maximum permissible differential pressure at which the motorized valve still closes securely against the pressure

Δp_{max} = Maximum permissible differential pressure across the valve's throughport for the entire positioning range of the motorized valve

Note



When using a stem heating element with a medium temperature of below $-5\text{ }^{\circ}\text{C}$, the stem sealing gland must be replaced. In this case, the sealing gland must be ordered separately.

DN	Stock number
DN 65...150	4 679 5629 0

Spare parts, Rev.-Nr.

See page 16

Accessories

Product number	Stock number	Description	Note	Example
ASZ6.6	S55845-Z108	Stem heating element	Required for medium temperatures $< 0\text{ }^{\circ}\text{C}$	
-	4 679 5629 0	Stem sealing gland	When using valves of the V..F43.. lines DN 65...150 with a stem heating element and a medium temperature below $-5\text{ }^{\circ}\text{C}$, the stem sealing gland must be replaced. With the gland 467956290 the valve can be used with water, water with antifreeze and brines between $-20\text{ }^{\circ}\text{C}$ and $150\text{ }^{\circ}\text{C}$.	

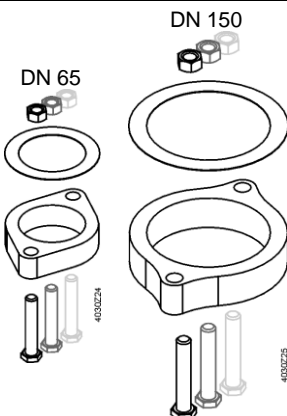
Adapter-type	Stock number	Bolts included	Description	VXF41..	Example
ALF41B65	S55845-Z114	4x M16x90mm	Adapter for replacing 3-port valves VXF41.. by VXF43.. • Due to different dimensions of the bypass flange • Every valve to be replaced requires an adapter • Adapter is supplied with the required number and size of bolts and nuts as well as two suitable flat sealings Replace 3-port valves VXF41..., DN 15...50 by 3-port valves VXF53.. (data sheet N4405).	DN 65	
ALF41B80	S55845-Z115	8x M16x110mm		DN 80	
ALF41B100	S55845-Z116	8x M16x110mm		DN 100	
ALF41B125	S55845-Z117	8x M16x110mm		DN 125	
ALF41B150	S55845-Z118	8x M20x110mm		DN 150	

Equipment combinations

Product number	Description	Stroke	Positioning force	Operating voltage	Positioning signal	Spring return time	Positioning time	LED	Manual adjuster	Auxiliary functions		
SAV31.00 ⁷⁾	S55150-A112	40 mm	1600 N	AC 230 V	3-position	-	120 s	-	Press and fix	1), 2), 5)		
SAV61.00 ⁷⁾ SAV61.00U ⁷⁾	S55150-A110 S55150-A110-A100			AC/DC 24 V	DC 0...10 V DC 4...24 mA 0...1000 Ω			✓		1), 3), 5), 6)		
SAV81.00 ⁷⁾ SAV81.00U ⁷⁾	S55150-A111 S55150-A111-A100			3-position	-			1), 2), 5)				
SKC32.60	SKC32.60	40 mm	2800 N	AC 230 V	3-position	-	120 s	-	Turn, Position is maintained	1), 2), 5)		
SKC32.61	SKC32.61			18 s	-	1), 3), 5)						
SKC60	SKC60			AC 24 V	0...10 V 4...20 mA 0...1000 Ω	20 s	Opening: 120 s Closing: 20 s	✓		1), 4), 5)		
SKC62 SKC62U	SKC62 SKC62U					3-position	-	120 s		-	1), 2), 5)	
SKC62UA	SKC62UA						18 s			-		
SKC82.60 SKC82.60U	SKC82.60 SKC82.60U											
SKC82.61 SKC82.61U	SKC82.61 SKC82.61U											

- 1) Auxiliary switch (optional)
2) Potentiometer (optional)
3) Position feedback, forced control, selection of valve characteristic
4) Direction of operation, stroke limit control, sequence control, signal addition (optional)
5) Stem heating element (optional)
6) Function module (optional)
7) SAV.. available in select countries only

Ordering

Example

Product number	Stock number	Description
VXF43.65-63	S55206-V115	3-port valve with flange, PN 16
SKC32.60	SKC32.60	Electro-hydraulic actuator

Delivery

Valves, actuators and accessories are packed and delivered as separate items.

Note





Counter-flanges, bolts and gaskets must be provided on site.

Product documentation

• Mounting Instructions	M4030 74 319 0749 0	DN 65...150
	A6V10774961 A5W90000815	DN 200, DN 250
• Basic documentation	P4030	Contains background information and technical basic knowledge of valves





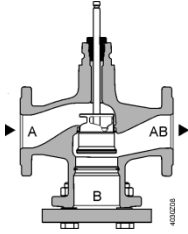
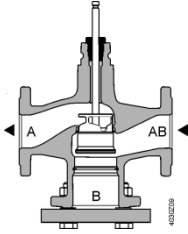

The illustrations below show the basic design of the valves. Constructional features, such as the shape of plugs, may differ.

2-port valves

 Fluids	 Steam (Fluids possible)
 Closing against the pressure	 Closing with the pressure
 <p>A → AB For use with all actuators</p>	 <p>A ← AB Use with electro-hydraulic actuators only</p>

2-port valves pressure compensated

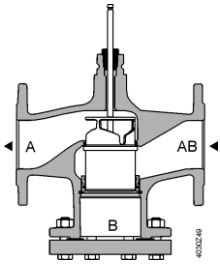
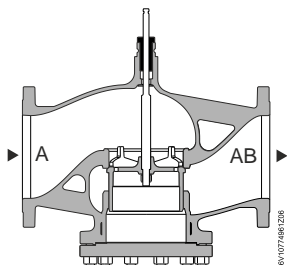

The VVF43..K valves use a pressure-compensated plug. This enables the same type of actuators to be used for the control of volumetric flow at higher differential pressures.

  DN 65...150 Fluids and Steam	  DN 200, DN 250 Fluids and Steam
 Closing with the pressure	 Closing against the pressure
 <p>A ← AB Use with electro-hydraulic actuators only</p>	 <p>A → AB Use with electro-hydraulic actuators only</p>

Note

2-port valves do not become 3-port valves by removing the blank flange!

3-port valves

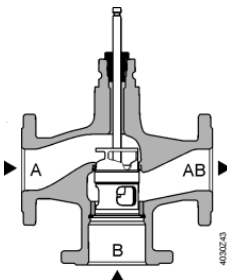
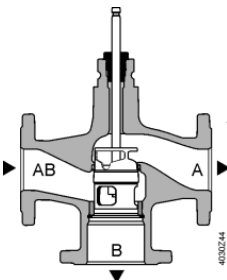
 Fluids	
 Mixing valve (preferred use)	 Diverting valve
 <p>A T → AB B</p>	 <p>AB T → A B</p>

Flow chart

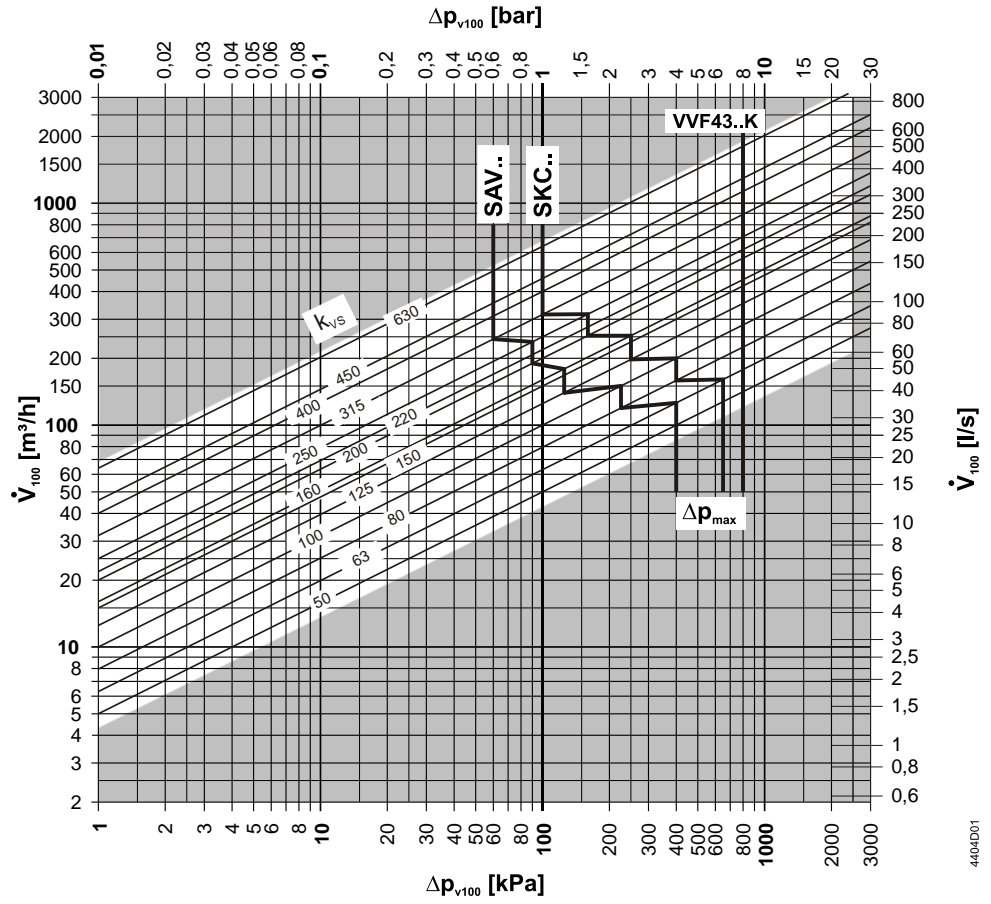

Δp_{max} values apply for the mixing function. Δp_{max} values for the diverting function see table „Type summary“, page 2

4404D01

Valve characteristics
2-port valves

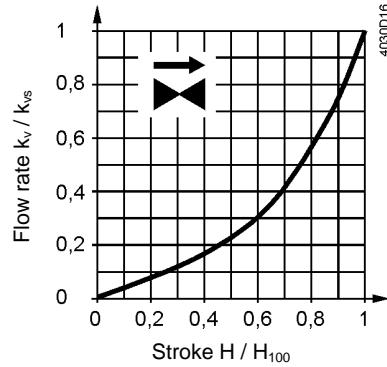

0...30 %: Linear
30...100 %: Equal percentage
 $n_{gl} = 3$ to VDI / VDE 2173

For high k_{vs} values the valve characteristic is optimized for maximum volumetric flow k_{V100} .

For product lines:

- VVF43.125-200
- VVF43.125-250
- VVF43.125-220K
- VVF43.150-315
- VVF43.150-400
- VVF43.150-315K
- VVF43.200-450K
- VVF43.250-630K

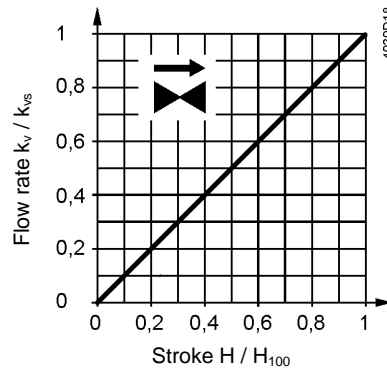

0...100 %: Linear

3-port valves

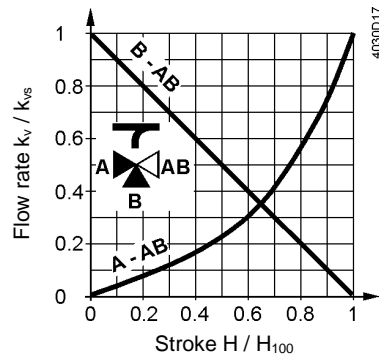

Throughport A-AB

0...30 %: Linear
30...100 %: Equal percentage
 $n_{gl} = 3$ to VDI / VDE 2173

For high k_{vs} values the valve characteristic is optimized for maximum volumetric flow k_{V100} .

Bypass B-AB

0...100 %: Linear
Port AB = constant flow
Port A = variable flow
Port B = bypass (variable flow)

Mixing: Flow from port A and port B to port AB
Diverting: Flow from port AB to port A and port B

For product lines:

- VXF43.125-250
- VXF43.150-400

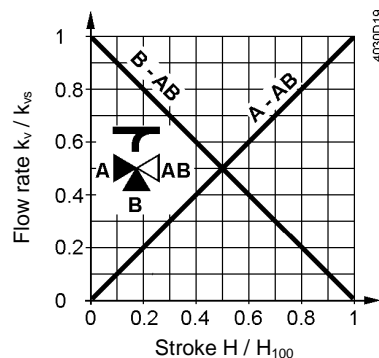

Throughport A-AB

0...100 %: Linear

Bypass B-AB

0...100 %: Linear

Operating pressure and medium temperature

Fluids
with V..F43..

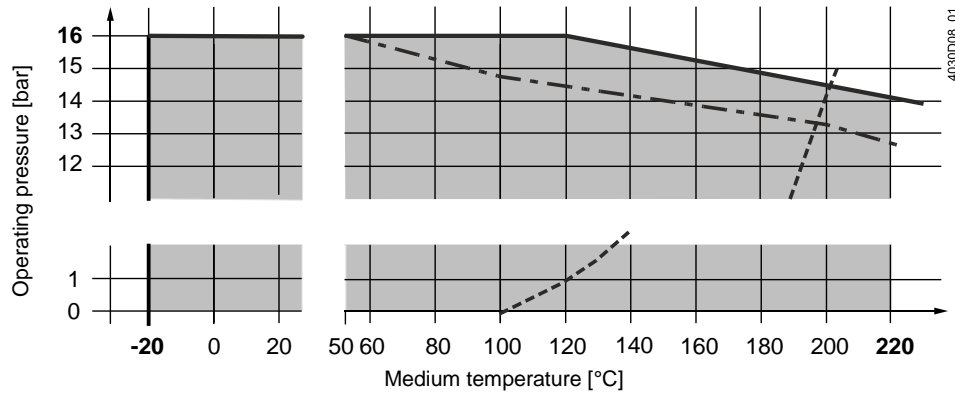

--- Curve for saturated steam; steam forms below this line

Operating pressure according to EN 1092-1, valid for 2-port valves with
- . . blank flange

Operating pressure and operating temperatures according to ISO 7005, EN 1092 and EN 12284

Notes

All relevant local directives must be observed

Saturated steam
Superheated steam
with VVF43..

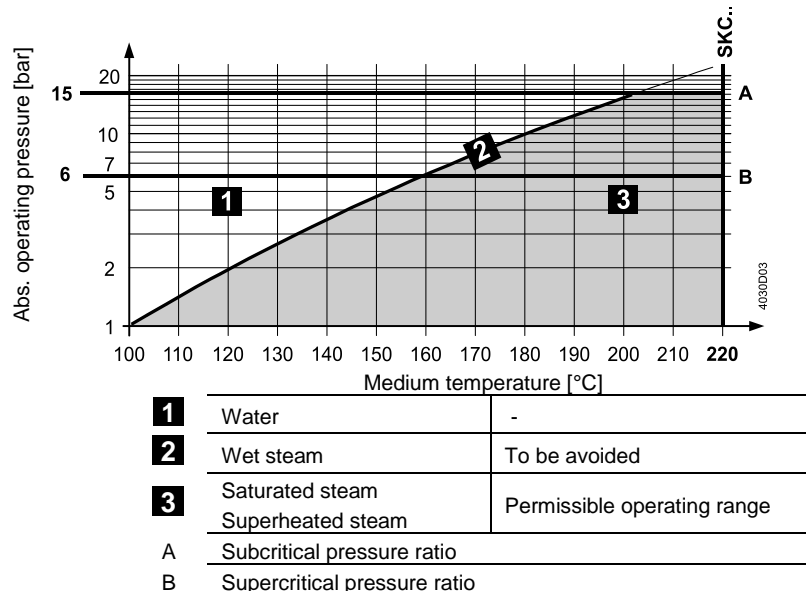

Medium compatibility and temperature ranges

Medium	Temperature range		Valve			Note
	T _{min} [°C]	T _{max} [°C]	VVF43..	VVF43..K	VXF43..	
Cold water	1	25	■	■	■	-
Low-temperature hot water	1	130	■	■	■	-
High-temperature hot water ¹⁾	130	150	■	■	■	-
	150	180	■	■	■	-
Water with antifreeze	-5	150	■	■	■	V..F43: With a medium temperature of below -5 °C, the stem sealing gland must be replaced by DN 65...150: 467956290
	-10	150	■	- ³⁾	■	
	-20	150	■	- ³⁾	■	
Cooling water ²⁾	1	25	■	■	■	-
Brines	-5	150	■	■	■	V..F43: With a medium temperature of below -5 °C, the stem sealing gland must be replaced by DN 65...150: 467956290
	-10	150	■	- ³⁾	■	
	-20	150	■	- ³⁾	■	
Saturated steam	100	150	■	■	-	-
	150	200	■	■	-	-
Superheated steam	120	150	■	■	-	-
	150	220	■	■	-	-
Heat transfer oils	20	220	■	■	■	On the basis of mineral oil
Super-clean water (demineralized and deionized water)	1	150	-	-	-	

¹⁾ Differentiation due to saturated steam curve

²⁾ Open circuits

³⁾ VVF43..K can't be used with media below -5 °C due to the compensation sealing material

Fields of use

Fields of use		valves	
		VVF43..	VXF43..
Generation	Boiler plants	■	■
	District heating plants	■	-
	Refrigeration plants	■	■
	Cooling towers ¹⁾	■	■
Distribution	Heating groups	■	■
	Air handling units	■	■

¹⁾ Open circuits

Engineering notes

Mounting location	Preferably mount the valves at the return, as the temperature is lower there and the strain on the stem sealing gland is lower.
Dirt trap	Mount a dirt filter or dirt trap before the valve to ensure proper functioning, and a long service life of the valve. Remove dirt, welding beads, etc. from the valves and pipes.
Cavitation	Cavitation can be avoided by limiting the pressure differential across the valve depending on the medium temperature and the prepressure.

Mounting notes

Mounting position

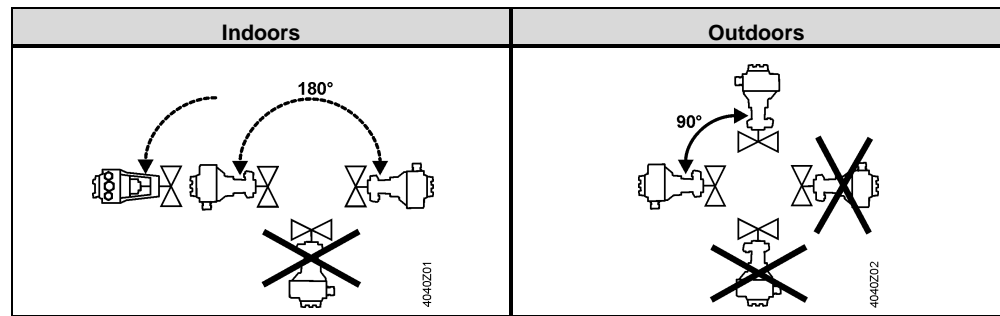

Mounting positions apply to both 2- and 3-port valves.

Commissioning notes



The valve may be put into operation only if actuator and valve are correctly assembled.

Note

Ensure that actuator stem and valve stem are rigidly connected in all positions.

Function check

Valve	Throughport A→AB or AB→A	Bypass B→AB
Valve stem extends	Closes	Opens
Valve stem retracts	Opens	Closes

Maintenance notes

The valves are maintenance-free.



When servicing valves or actuators:

- Deactivate the pump and turn off the power supply
- Close the shutoff valves
- Fully reduce the pressure in the piping system and allow pipes to completely cool down

If necessary, disconnect the electrical wires.

Disposal

Do not dispose of the device as unsorted municipal waste.

- Special handling of individual components may be mandated by law or make ecological sense.
- Observe all local and currently applicable laws and regulations.

Warranty

Application-related technical data are guaranteed only when the valves are used in connection with the Siemens actuators listed under "Equipment combinations", page 3.

When used with actuators of other manufacture, any warranty by Siemens becomes void.

Technical Data

Functional data	PN class	PN 16	
	Connection	Flange	
	Operating pressure	See Section "Operating pressure and medium temperature", page 8	
	Valve characteristics ¹⁾	See section "Valve characteristics", page 7	
	Leakage rate	Throughport	DN 65...150: 0...0.01 % of k_{vs} value (Class IV) DN 200, DN 250: 0...0.02 % of k_{vs} value
		Bypass	0.5...2% of k_{vs} value with SKC.. 0.05% of k_{vs} value with SAV..
	Permissible media	See table "Medium compatibility and temperature ranges", page 9	
	Medium temperature	-20...220 °C ²⁾ VVF43..K: -5...220 °C	
	Rangeability	DN 65...150:	>100
		DN 200, DN 250:	>50
	Nominal stroke	40 mm	
Materials	Valve body	DN 65...150: EN-GJS-400-18-LT DN 200, DN 250: ASTM A216WCB (GP240GH)	
	Blank flange	DN 65...150: P265GH DN 200, DN 250: CK25	
	Valve stem, seat, plug	Stainless steel	
	Stem sealing gland	Stainless steel	
		DN 65...150: FEPM (silicone-free) DN 200, DN 250: PTFE (not silicone-free)	
	Compensation sealing	Stainless steel	
		DN 65...150: FEPM (silicone-free) DN 200, DN 250: PTFE+carbon (not silicone-free)	
Adapter ALF41B..	Steel S235JRG2		
Norms and standards	Pressure Equipment Directive	PED 2014/68/EU	
	Pressure Accessories	Scope: Article 1, section 1 Definition: Article 2, section 5	
	Fluid group 2:		
	DN 65...125	Category I, Module A, with CE-marking as per article 14, section 2	
	DN 150	Category II, Module A2, with CE-marking, as per article 14, section 2 notified body number 0036	
	DN 200, DN 250	Category II, Module A2, with CE-marking, as per article 14, section 2 notified body number 0035	
	EU Conformity (CE):		
	DN 65...150	A5W00006523 ³⁾	
	DN 200, DN 250	A5W90001026 ³⁾	
	PN class	ISO 7268	
	Operating pressure	ISO 7005, DIN EN 12284	
	Flanges	ISO 7005	
	Length of flanged valves	DIN EN 558-1, line 1	
	Valve characteristic	VDI 2173	
	Leakage rate	Throughport, bypass according to EN 60534-4 / EN 1349	
Water treatment	VDI 2035		

Environmental conditions	Storage: IEC 60721-3-1	Class	1K3
		Temperature	-15...55 °C
		Rel. humidity	5...95% r.h.
	Transport: IEC 60721-3-2	Class	2K3, 2M2
		Temperature	-30...65 °C
		Rel. humidity	< 95% r.h.
	Operation: IEC 60721-3-3	Class	3K5, 3Z11
		Temperature	-15...55 °C
		Rel. humidity	5...95% r.h.
Environmental compatibility	The product environmental declaration CE1E4404en01 ³⁾ , CE1E4404en02 ³⁾ and A5W90001031 ³⁾ contains data on environmentally compatible product design and assessments (RoHS compliance, materials composition, packaging, environmental benefit, disposal).		
Dimensions / Weight	Dimensions	See "Dimensions", page 13 + 14	
	Weight	See "Dimensions", page 13 + 14	

- ¹⁾ For certain valve lines and high k_{vS} values, the valve characteristic is optimized for maximum volumetric flow k_{V100}
- ²⁾ For medium temperatures < -5 °C, the stem sealing gland must be replaced. The sealing gland must be ordered separately (Stock number: 4 679 5629 0).
- ³⁾ The documents can be downloaded from <http://www.siemens.com/bt/download>.

Dimensions

VVF43..

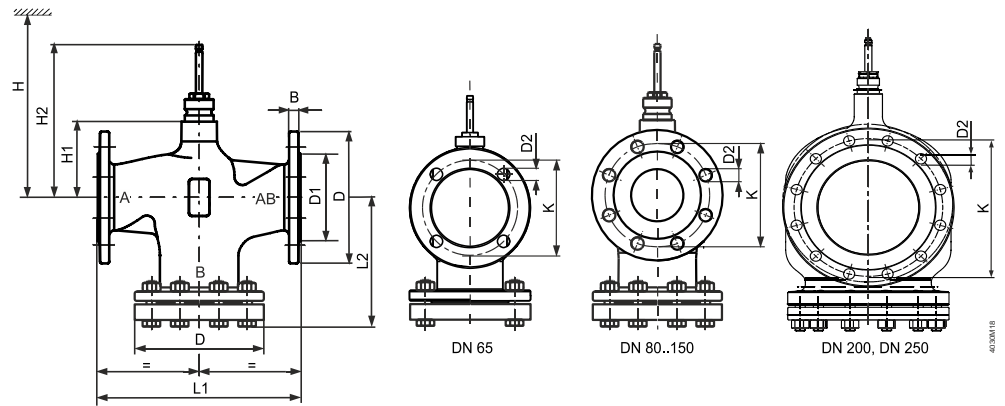

Product number	DN	B	Ø D	Ø D1	Ø D2	L1	L2	Ø K	H1	H2	H		
											SAV..	SKC..	
VVF43..	65	21.5	17	185	118	19 (4x)	290	178	145	115	231.5	580	690
	80	27.5	17	200	132	19 (8x)	310	190	160	115	231.5	580	690
	100	33.8	17	220	156	19 (8x)	350	206	180	146	262.5	611	721
	125	45.8	17	250	184	19 (8x)	400	233	210	159	275.5	624	734
	150	67.9	17	284	211	23 (8x)	480	275.5	240	186.5	303	652	762
VVF43..K	65	21.5	17	185	118	19 (4x)	290	178	145	115	231.5	-	690
	80	27.6	17	200	132	19 (8x)	310	190	160	115	231.5	-	690
	100	34.1	17	220	156	19 (8x)	350	206	180	146	262.5	-	721
	125	46.7	17	250	184	19 (8x)	400	233	210	159	275.5	-	734
	150	68.7	17	284	211	23 (8x)	480	275.5	240	186.5	303	-	762
	200	130	30	340	266	22 (12x)	600	265	295	243	359.5	-	818
	250	196	32	405	319	26 (12x)	730	290	355	275	391.5	-	850

VXF43..

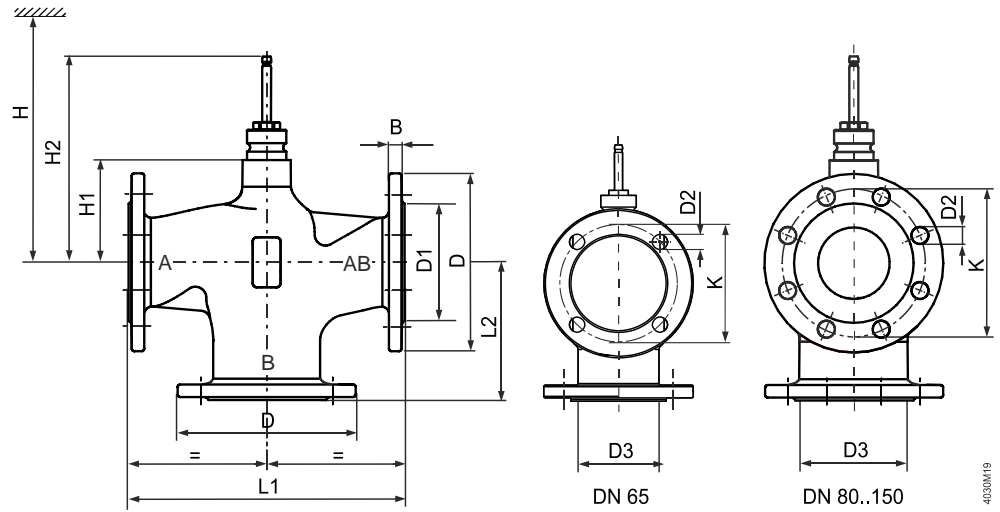



4000M19

Product number	DN	kg	B	Ø D	Ø D1	Ø D2	Ø D3 ¹⁾	L1	L2	Ø K	H1	H2	H	
													SAV..	SKC..
VXF43..	65	16.5	17	185	118	19 (4x)	86	290	145	145	115	231.5	580	690
	80	20.7	17	200	132	19 (8x)	100	310	155	160	115	231.5	580	690
	100	26.9	17	220	156	19 (8x)	123	350	175	180	146	262.5	611	721
	125	36.4	17	250	184	19 (8x)	149	400	200	210	159	275.5	624	734
	150	54.9	17	284	211	23 (8x)	174	480	240	240	186.5	303	652	762

¹⁾ Interior opening of the bypass port

Spare parts

Stem sealing gland

Product number	DN	Stock number	Comments	
VVF43.. VXF43.. VVF43..K	DN 65...150 Series A, B and C	74 284 0061 0	Standard version with FEPM-O-ring for medium temperatures between -5 °C and 220 °C	
VVF43.. VXF43.. VVF43..K	DN 65...150 As from series D	S55846-Z114	Standard version with FEPM-O-ring for medium temperatures between -5 °C and 220 °C.	
VVF43.. K	DN 200, DN 250	4 679 5630 0	Standard version with PTFE sleeve for medium temperatures between -5 °C and 220 °C.	
VVF43.. VXF43..	DN 65...150	4 679 5629 0	When operating with medium temperatures below -5 °C . With the gland 467956290 the valve can be used with water, water with antifreeze and brines between -20 °C and 150 °C.	
VVF43.. VVF43..K	DN 65...150	4 679 5629 0	When operating with medium temperatures below -5 °C . With the gland 467956290 the valve can be used with water, water with antifreeze and brines between -20 °C and 150 °C.	
VXF43..	DN 65...150 series A, B and C	74 284 0061 0	Standard version with PTFE sleeve for medium temperatures between -5 °C and 220 °C.	
VXF43..	DN 65...150 As from series D	S55846-Z114	Standard version with PTFE sleeve for medium temperatures between -5 °C and 220 °C.	
VVF43.. VVF43..K	DN 200, DN 250	4 679 5630 0	Standard version with PTFE sleeve for medium temperatures between -5 °C and 220 °C.	

Revision numbers

Product number	Valid from rev. no.	Product number	Valid from rev. no.
VVF43.65-50	..D	VXF43.65-50	..D
VVF43.65-63	..D	VXF43.65-63	..D
VVF43.80-80	..D	VXF43.80-80	..D
VVF43.80-100	..D	VXF43.80-100	..D
VVF43.100-125	..D	VXF43.100-125	..D
VVF43.100-160	..D	VXF43.100-160	..D
VVF43.125-200	..D	VXF43.125-200	..D
VVF43.125-250	..D	VXF43.125-250	..D
VVF43.150-315	..D	VXF43.150-315	..D
VVF43.150-400	..D	VXF43.150-400	..D
VVF43.65-63K	..D		
VVF43.80-100K	..D		
VVF43.100-150K	..D		
VVF43.125-220K	..D		
VVF43.150-315K	..D		
VVF43.200-450K	..A		
VVF43.250-630K	..A		

Issued by
 Siemens Switzerland Ltd
 Building Technologies Division
 International Headquarters
 Theilerstrasse 1a
 6300 Zug
 Switzerland
 Tel. +41 58-724 24 24
www.siemens.com/buildingtechnologies

© Siemens Switzerland Ltd, 2011
 Technical specifications and availability subject to change without notice.

ACVATIX™

Electro-hydraulic actuators for valves

SKC..



with 40 mm stroke

- SKC32.. operating voltage AC 230 V, 3-position control signal
- SKC82.. operating voltage AC 24 V, 3-position control signal
- SKC6.. op. voltage AC 24 V, control signal DC 0...10 V, 4...20 mA, 0...1000 Ω
 - SKC62/MO RS-485 for Modbus RTU communication
 - Selectable flow characteristic, position feedback, stroke calibration, LED status indication, override control
 - SKC62UA with selection of direction of operation, stroke limit control, sequence control with adjustable start point and operating range, operation of frost protection monitors QAF21.. and QAF61..
- Positioning force 2800 N
- For direct mounting on valves; no adjustments required
- With hand crank and position indication; optionally with/out spring-return function
- Optional functions with auxiliary switches, potentiometer and stem heater
- SKC..U are UL-approved

For the operation of Siemens 2-port and 3-port valves of the series VVF.. and VXF.. with 40 mm stroke as control and safety shut-off valves in heating, ventilation and air conditioning plants.

Principle of electro-hydraulic actuators

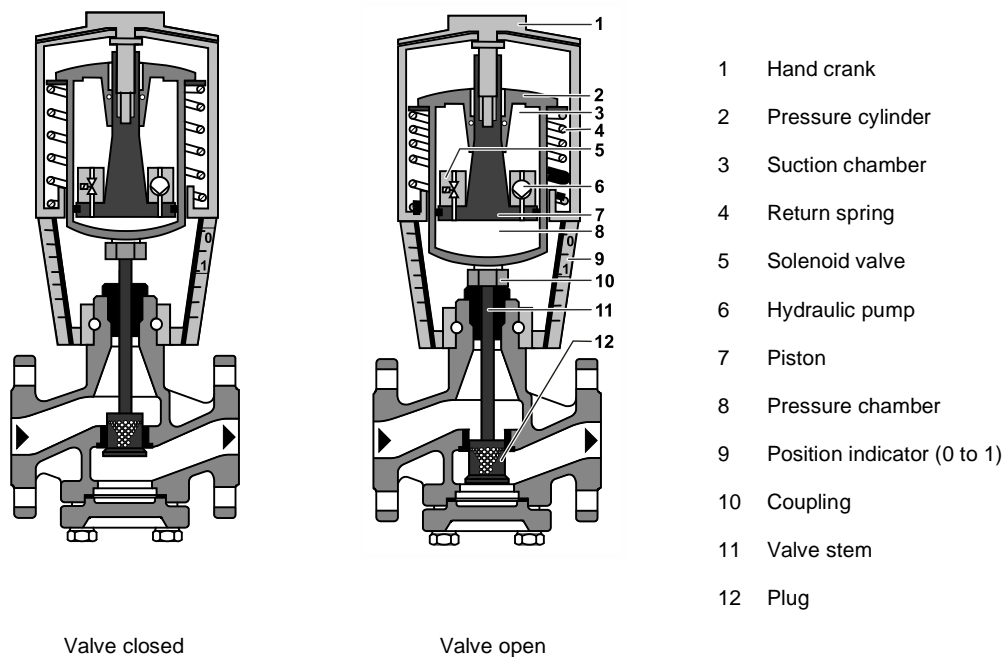

Opening the valve

The hydraulic pump [6] forces oil from the suction chamber [3] into the pressure chamber [8], thereby moving the pressure cylinder [2] downwards. The valve stem [11] retracts and the valve opens. Simultaneously, the return spring [4] is compressed.

Closing the valve

Activating the solenoid valve [5] allows the oil in the pressure chamber to flow back into the suction chamber. The compressed return spring moves the pressure cylinder upwards. The valve stem extends and the valve closes.

Manual operation mode

For manual operation, swing out the crank so that the display window becomes visible. By rotating the crank clockwise, the pressure cylinder is moved downwards. The display window shows the engagement bar and/or the scale dial with stroke indication.

In manual operation mode, the positioning signals Y and Z can further open the valve, but cannot close to the 0 % stroke position of the valve. To retain the manually set position, switch off the power supply or disconnect the positioning signals Y and Z. The crank remains swung out and the red indicator dial remains visible in the display window.



When setting the controller to manual operation for a longer period of time, we recommend adjusting the actuator with the hand crank to the desired position. This guarantees that the actuator remains in this position for that period of time.

Attention: Do not forget to switch back to automatic operation after the controller is set back to automatic control.

Automatic operation mode

For automatic operation, turn the hand crank clockwise to the end stop - position 0 % - until the read scale disappears in the display window. Afterwards, swing the crank closed.

Minimum volume flow

The actuator can be manually adjusted to a stroke position > 0 %, allowing its use in applications requiring a constant minimum volume flow.

SKC32.., SKC82.. 3-position control signal

The actuator is controlled by a 3-position signal via either terminal Y1 or Y2, and generates the desired stroke, which is transferred to the valve stem:

- Voltage on Y1: Piston extends Valve opens
- Voltage on Y2: Piston retracts Valve closes
- No voltage on Y1 and Y2: Piston and valve stem remain in the respective positions

SKC62.., SKC60 Y positioning signal - DC 0...10 V and/or 0...1000 Ω, DC 4...20 mA

The actuator is controlled either via terminal Y or override control Z. The positioning signals generate the desired stroke, which is transferred to the valve stem, by means of the above described principle of operation:

- Signal Y increasing: Piston extends Valve opens
- Signal Y decreasing: Piston retracts Valve closes
- Signal Y constant: Piston and valve stem remain in the respective positions
- Override control Z: See "Functions [▶ 7]"

Frost protection thermostat, frost protection monitor

A frost protection thermostat can be connected to the SKC6.. actuator.

The added signals from the frost protection monitors QAF21.. and QAF61.. require the use of SKC62UA actuators. Notes on special programming of the electronics can be found in "Electronics [▶ 5]".

Connection diagrams for operation with frost protection thermostat or monitor can be found in "Connection diagrams [▶ 27]".

SKC60 ¹⁾

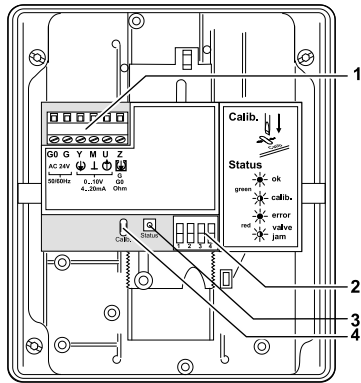

- 1 Connection terminals
- 2 DIL switches
- 3 LED status indication
- 4 Stroke calibration

¹⁾ From version ..L onward



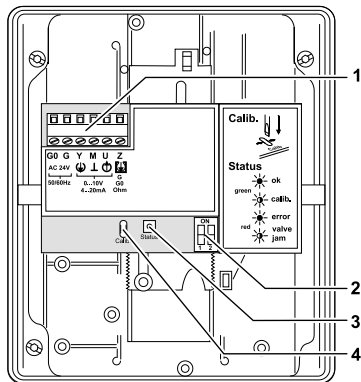

DIL switches								
	Direction of operation		Fail-in-place (behavior in case of control signal loss) **		Positioning signal Y Positioning feedback U		Flow characteristic	
ON		Reverse acting		Stops at current position		DC 4...20 mA		lin = linear
OFF *		Direct acting		Closes		DC 0...10 V		log = equal percentage
					Relationship between positioning signal Y and volume flow			
* Factory setting: all switches "OFF"								
** Only considered when DIL switch 3 "ON" (positioning signal = DC 4...20 mA)								

SKC60 ²⁾, SKC62..



- 1 Connection terminals
- 2 DIL switches
- 3 LED status indication
- 4 Stroke calibration



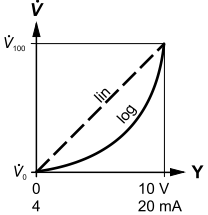



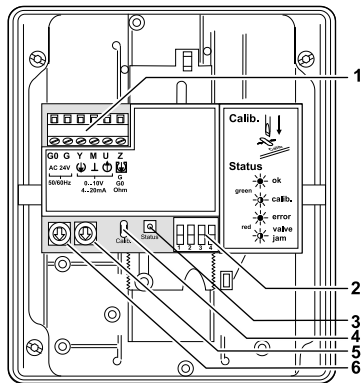

²⁾ Up to and including version ..K

DIL switches				
	Positioning signal Y Positioning feedback U		Flow characteristic	
ON		DC 4...20 mA		lin = linear
OFF *		DC 0...10 V		log = equal percentage
			Relationship between positioning signal Y and volume flow	
* Factory setting: all switches "OFF"				

SKC62UA

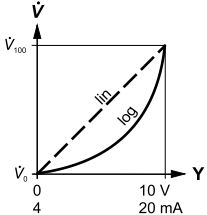

- 1 Connection terminals
- 2 DIL switches
- 3 LED status indication
- 4 Stroke calibration
- 5 Rotary switch UP (*factory setting 0*)
- 6 Rotary switch LO

DIL switches								
	Direction of operation		Sequence control or stroke limit control		Positioning signal Y Positioning feedback U		Flow characteristic	
ON		Reverse acting		Sequence control Signal addition QAF21../QAF61..		DC 4...20 mA		lin = linear
OFF *		Direct acting		Stroke limit control		DC 0...10 V		log = equal percentage
					Relationship between positioning signal Y and volume flow			
* Factory setting: all switches "OFF"								

SKC62/MO

The Modbus converter is designed for analog control at 0...10 V.



Keep the analog signal setting on the actuator as is (switch 1 "OFF"); adjustment not permitted.

The actuators are factory set for equal-percentage characteristic.



Actuator-internal characteristic changeover must remain set to "log" (switch 2 "OFF").

Functions

Spring-return function

The SKC32.61.., SKC82.61.. and SKC62.. actuators, which feature a spring-return function, incorporate a solenoid valve which opens if the control signal or power fails. The return spring causes the actuator to move to the "0 %" stroke position and closes the valve.

Stroke calibration

SKC60, SKC62.., SKC62/MO

In order to determine the stroke positions 0 % and 100 % in the valve, calibration is required on initial commissioning.

- ✓ Actuator SKC6.. mechanically coupled with a Siemens valve.
 - ✓  **Actuator must be in "Automatic operation mode" enabling stroke calibration to capture the effective 0 % and 100 % values.**
 - ✓ AC 24 V power supply applied.
 - ✓ Housing cover removed.
 1. Short-circuit contacts in calibration slot (e.g. with a screwdriver) and trigger calibration process.
 2. Actuator moves to "0 %" stroke position[1].
 - ⇒ Valve closes.
 3. Actuator moves to "100 %" stroke position [2].
 - ⇒ Valve opens.
- ⇒ Measured values are saved.
- ⇒ Normal operation:
Actuator moves to the position indicated by signal Y or Z [3].
LED lit steadily green, positioning feedback U active, values correspond to the actual positions.

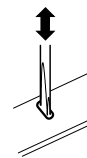

LED flashes green, positioning feedback U inactive

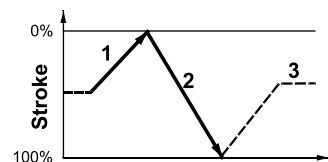

A calibration error is indicated by the LED on the actuator lighting up red.







The LED on the SKC62/MO cable adapter flashes red during the calibration, as the positioning signal Y and the positioning feedback U do not correspond anymore. This is interpreted as a jam and thus indicated as an error.

If necessary, the calibration can be repeated any number of times.

LED status indication SKC60, SKC62.., SKC62/MO

The dual-colored LED indicating the operational status is visible when the cover is removed.

LED indication	Function	Note, trouble shooting
 Lit green	Normal operation	Automatic operation; everything OK
 Flashing green	Stroke calibration in progress	Wait until calibration is finished (LED stops flashing, instead lit green or red)
 Lit red	Faulty stroke calibration	Check mounting; restart stroke calibration (by short-circuiting calibration slot)
	Internal error	Replace electronics
 Flashing red	Inner valve jammed	Trouble shoot, check valve, restart stroke calibration
 Off	No power supply	Check mains network, check wiring
	Electronics faulty	Replace electronics

The LED can exclusively assume the states shown above - continuously lit red or green, flashing red or green, or off/dark.

Override control Z SKC60, SKC62..

The override control input Z can be operated in the following modes of operation:

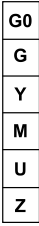
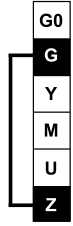
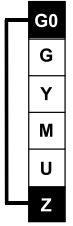
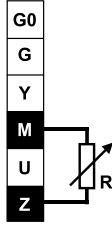
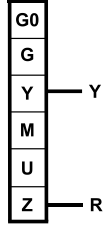
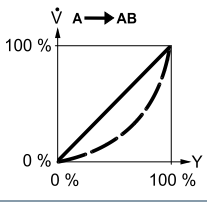
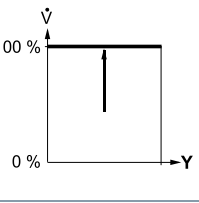
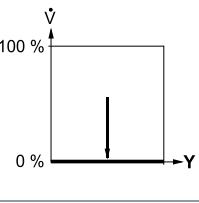
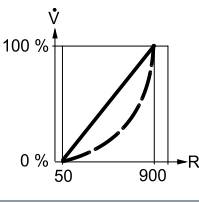
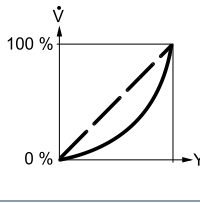
Z mode					
	No function	Fully open	Closed	Override with 0...1000 Ω	Signal addition SKC62UA only
Connections					
Transfer					
	Equal percentage or linear characteristic			Equal percentage or linear characteristic	
	<ul style="list-style-type: none"> Z contact not connected 	<ul style="list-style-type: none"> Z contact connected directly to G 	<ul style="list-style-type: none"> Z contact connected directly to G0 	<ul style="list-style-type: none"> Z contact connected to M via resistor R Starting pos. at 50 Ω End pos. at 900 Ω 	<ul style="list-style-type: none"> Z contact connected to R of frost protection monitor QAF21.. or QAF61..
	<ul style="list-style-type: none"> Valve stroke follows Y input 	<ul style="list-style-type: none"> Y input has no effect 		<ul style="list-style-type: none"> Valve stroke follows Y and R(Z) signal 	



Shown operation modes are based on the factory setting "direct acting".

Y input has no effect in Z mode.

Selection of direction of operation SKC60 (from version ..L), SKC62UA

- With NC (= normally closed) valves, "direct acting" means that with a signal input of 0 V, the valve closes (applies to all Siemens valve listed in "Equipment combinations [▶ 12]").
- With NO (= normally open) valves, "direct acting" means that with a signal input of 0 V, the valve is open.

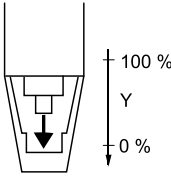
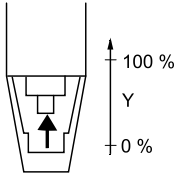
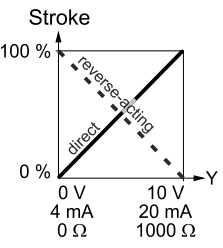
Direct acting		Reverse acting		Stroke
				
Input	DC 0...10 V DC 4...20 mA 0...1000 Ω	Input	DC 0...10 V DC 4...20 mA 0...1000 Ω	



The mechanical spring-return function is not affected by the selection of the direction of operation.

Stroke control with QAF21.. / QAF61.. signal addition SKC62UA

Setting the signal addition			
The operating range of the frost protection monitor QAF21.. or QAF61.. can be defined with rotary switches LO and UP.			
Position of LO	Sequence control start point	Position of UP	QAF21.. / QAF61.. operating range
0	→	1	QAF21..
0	→	2	QAF61..

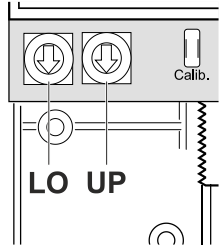

Stroke limit control and sequence control SKC62UA

Stroke limit control setting	Sequence control setting
<p>The rotary switches LO and UP can be used to apply a lower and upper limit to the stroke, in increments of 3 %, up to a maximum of 45 %.</p>	<p>The rotary switches LO and UP can be used to determine the start point or the operating range of a sequence.</p>

Position of LO	Lower stroke limit	Position of UP	Upper stroke limit		Position of LO	Sequence control start point	Position of UP	Sequence control operating range
0	0 %	0	100 %		0	0 V	0	10 V
1	3 %	1	97 %		1	1 V	1	10 V *
2	6 %	2	94 %		2	2 V	2	10 V **
3	9 %	3	91 %		3	3 V	3	3 V ***
4	12 %	4	88 %		4	4 V	4	4 V
5	15 %	5	85 %		5	5 V	5	5 V
6	18 %	6	82 %		6	6 V	6	6 V
7	21 %	7	79 %		7	7 V	7	7 V
8	24 %	8	76 %		8	8 V	8	8 V
9	27 %	9	73 %		9	9 V	9	9 V
A	30 %	A	70 %		A	10 V	A	10 V
B	33 %	B	67 %		B	11 V	B	11 V
C	36 %	C	64 %		C	12 V	C	12 V
D	39 %	D	61 %		D	13 V	D	13 V
E	42 %	E	58 %		E	14 V	E	14 V
F	45 %	F	55 %		F	15 V	F	15 V

* Operating range QAF21.. (see "Stroke control with QAF21.. / QAF61.. signal addition", "Functions [► 8]")

** Operating range QAF61.. (see "Stroke control with QAF21.. / QAF61.. signal addition", "Functions [► 8]")

*** The smallest adjustment possible is 3 V; control with 0...30 V is only possible via Y.

Type summary

Type			Operating voltage	Positioning signal	Spring-return		Positioning time		
	Stock no.	Electronics			Function	Time	Opening	Closing	
SKC32.60 ¹⁾	BPZ:SKC32.60	-	AC 230 V	3-position	-		120 s	120 s	
SKC32.60/F ^{1), 3)}	BPZ:SKC32.60/F				-				
SKC32.61 ¹⁾	BPZ:SKC32.61				yes	18 s			
SKC32.61/F ^{1), 3)}	BPZ:SKC32.61/F				-				
SKC82.60 ¹⁾	BPZ:SKC82.60		-		120 s	120 s			
SKC82.60U ²⁾	BPZ:SKC82.60U		-						
SKC82.61 ¹⁾	BPZ:SKC82.61		yes						18 s
SKC82.61U ²⁾	BPZ:SKC82.61U		-						
SKC60 ^{1), 4)}	BPZ:SKC60	Standard	AC 24 V	DC 0...10 V 4...20 mA 0...1000 Ω	-		20 s	20 s	
SKC62 ¹⁾	BPZ:SKC62				-				
SKC62/F ^{1), 3)}	BPZ:SKC62/F				yes	20 s			
SKC62U ²⁾	BPZ:SKC62U				-				
SKC62UA ^{2), 5)}	BPZ:SKC62UA	Enhanced							
SKC62/MO ²⁾	S55195-A128	Standard		Modbus RTU					

¹⁾ Approval: CE

²⁾ Approval: CE, UL

³⁾ Only available in France

⁴⁾ Additional functions (from version ..L): direction of operation, fail-in-place

⁵⁾ Additional functions: direction of operation, stroke control limit, sequence control, signal addition

Scope of delivery

The actuator, valve and accessories are supplied in separate packaging and not assembled prior to delivery.

Ordering example

Type / Stock no.	Designation	Quantity
SKC62/MO / S55195-A128	Actuator Modbus RTU	1
ASC1.6 / BPZ:ASC1.6	Auxiliary switch	1

Accessories

Type	Auxiliary switch	Double auxiliary switch	Potentiometer 1000 Ω	Stem heater AC 24 V
	ASC1.6	ASC9.3	ASZ7.3	ASZ6.6 [S55845-Z108]
	Total max. 2			
SKC32..	-	Max. 1	Max. 1	Max. 1
SKC82..				
SKC6..	Max. 1	-	-	

- SKC..** **ASZ6.6** [S55845-Z108]
 Stem heater
- For media below 0 °C
 - Mount between valve and actuator

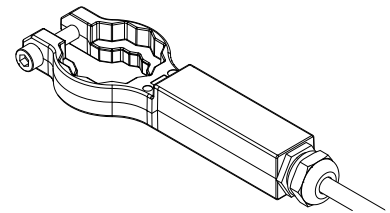

- SKC32..** **ASC9.3** [BPZ:ASC9.3]
SKC82.. Double auxiliary switch
- Adjustable switching points

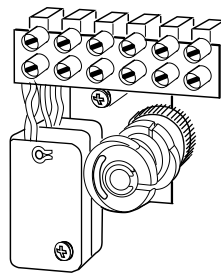

- ASZ7.3** [BPZ:ASZ7.3]
 Potentiometer
- 0...1000 Ω

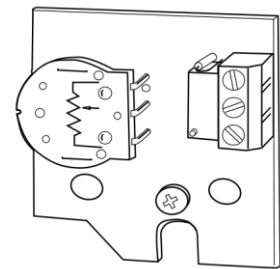

- SKC60** **ASC1.6** [BPZ:ASC1.6]
SKC62.. Auxiliary switch
- Switching point 0...5 % stroke

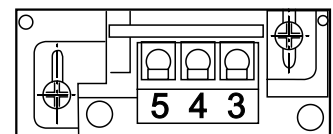

ASZ7.3

For the combination SIMATIC S5/S7 and use of positioning feedback, we recommend actuators with DC 0...9.8 V feedback signals.

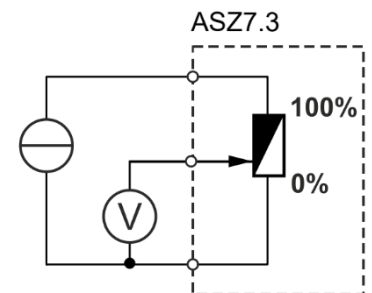

The signal peaks occurring in the potentiometer ASZ7.3 may result in error messages on Siemens SIMATIC. This is not the case when combined with Siemens HVAC controllers. The reason is that SIMATIC has a higher resolution and faster response time.

Use the potentiometer as voltage divider on the 3-wire connection. Powering the potentiometer over the wiper may shorten the life cycle of the potentiometer. Signal peaks increase in frequency and scope over the lifespan in this operating mode.

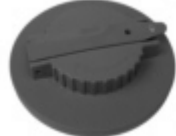

For more information, see "Technical data [▶ 19]".

Spare parts

Actuator	Cover	Hand crank ¹⁾	Clamp	Stem connection	Electronics (control unit)
					
SKC32.60, SKC32.60/F	410455828	426855108	410355768	417856498	-
SKC32.61, SKC32.61/F					
SKC82.60					
SKC82.60U					
SKC82.61					
SKC82.61U					
SKC60			466857598		
SKC62, SKC62/F			466857488		
SKC62U			466857518		
SKC62UA			466857488		
SKC62/MO					

¹⁾ Hand crank, blue with mechanical parts

Equipment combinations

2-port valves VV.. (control or safety shut-off valves)

Valve type		DN	PN class	k _{vs} [m ³ /h]	Data sheet
VVF21.. ¹⁾	Flanged	100	6	124...160	N4310
VVF22..				160	N4401
VVF31.. ¹⁾		100...150	10	124...315	N4320
VVF32..				160...400	N4402
VVF40.. ¹⁾				65...150	16
VVF41.. ¹⁾		49...300	N4340		
VVF45..			N4345		
VVF43..		15...80	50...400		
VVF42..		100...150	25	125...400	N4403
VVF53..		65...150		63...400	N4405
VVF61..		15...50	40	49...300	N4382
VVF63..				50...315	A6V11459527

Permissible differential pressure Δp_{max} and closing pressure Δp_s : cf. relevant valve data sheets

¹⁾ Valves no longer available

3-port valves VX.. (control valves for mixing and distribution)

Valve type		DN	PN class	k _{vs}	Data sheet
				[m ³ /h]	
VXF21.. ¹⁾	Flanged	100	6	124...160	N4410
VXF22..				160	N4401
VXF31.. ¹⁾		100...150	10	124...315	N4420
VXF32..				160...400	N4402
VXF40.. ¹⁾		65...150	16	124...315	N4430
VXF41.. ¹⁾				49...300	N4440
VXF43..		100...150	25	63...400	N4404
VXF42..				125...400	N4403
VXF53..		65...150	40	63...400	N4405
VXF61..				49...300	N4482

Permissible differential pressure Δp_{\max} and closing pressure Δp_s : cf. relevant valve data sheets

¹⁾ Valves no longer available



Third-party valves with strokes between 6...20 mm can be motorized, provided they have "closed in de-energized state" fail-safe mechanisms and provided that the necessary mechanical coupling is available. For SKC32.. and SKC82.., the Y1 signal must be routed via an additional, freely adjustable end switch (ASC9.3) to limit the stroke.

We recommend that you contact your local Siemens office for the necessary information.

Product documentation

SKC..			Accessories	Mounting instructions	
Mounting instructions SKC..	M3240	74 319 0324 0	ASC1.6	G4563.3	4 319 5544 0
74 319 0326 0 (Setting instructions standard electronics)			ASC9.3	G4561.3	4 319 5545 0
			ASZ7.3	74 319 0247 0	
A5W00027551 (Mounting instructions Modbus converter)			ACT control unit	M4568	74 319 0554 0
			QAF21..	74 319 0399 0	
A6V12057657 (Modbus communication profiles)			ASZ6.6	M4501.1	74 319 0750 0

Related documents such as environmental declarations, CE declarations, etc., can be downloaded at the following Internet address:

<http://siemens.com/bt/download>

Safety

⚠ CAUTION**National safety regulations**

Failure to comply with national safety regulations may result in personal injury and property damage.

- Observe national provisions and comply with the appropriate safety regulations.

⚠ WARNING**Tensioned return spring**

Opening the actuator housing can release the highly tensioned return spring, which can lead to flying parts and injuries.

- Do not open the actuator housing.

⚠ WARNING**Risk of injury through broken housing or cover**

Dismounting the actuator with broken housing from the valve can release the highly tensioned return spring, which can lead to flying parts and injuries.

- NEVER dismount actuator from valve.
- Dismount valve-actuator combination (control device) as complete unit.
- Disassembly only by qualified personnel.
- Send the control device along with an error report to the local Siemens office for analysis and disposal.
- Mount new control device (valve and actuator) properly.

⚠ WARNING**Risk of burns from hot actuator brackets**

The actuator brackets on heating plants will become hot from contact with the hot valve during operation. The temperature of the actuator bracket can reach 100 °C.

When servicing the actuator:

- Switch off both pump and operating voltage.
- Close the main shut-off valve in the piping.
- Release pressure in the pipes and allow them to cool off completely.

Engineering

Perform the electrical connections in accordance with local regulations on electrical installations, as well as the section "Connection diagrams [▶ 27]".

NOTICE	
	<p>Using a safety limiter</p> <p>Failure to comply with the applicable regulations for cable insulation may result in the suspension of the safety limiter function.</p> <ul style="list-style-type: none"> Compliance with all applicable regulations for cable insulation must be ensured by the plant operator.

⚠ WARNING	
	<p>Risk of injury and fire from hot device parts</p> <p>For media below 0 °C, the stem heater ASZ6.6 keeps the valve stem free of ice. In this case, the actuator bracket and the valve stem must not be insulated in order to ensure air circulation.</p> <p>Touching heated parts without safety measures leads to burns.</p> <ul style="list-style-type: none"> For safety reasons, the stem heater is operated with AC 24 V / 30 W. <p>Recommendation: For media above 140 °C, the valve must be insulated.</p>

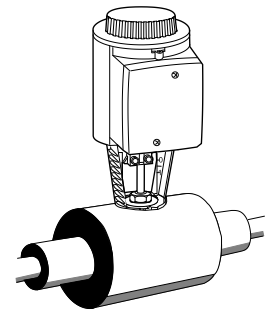

Observe permissible temperatures, see "Use [▶ 2]" and "Technical data [▶ 19]".

If an auxiliary switch is used, its switching point should be indicated on the plant schematic.

Every actuator must be driven by a dedicated controller, see "Connection diagrams [▶ 27]".

Mounting

The mounting instructions M3240 / 74 319 0324 0 for fitting the actuator to the valve and A5W00027551 for SKC62/MO are enclosed in the actuator packaging. The instructions for accessories are enclosed with the accessories themselves (see "Product documentation [▶ 13]").

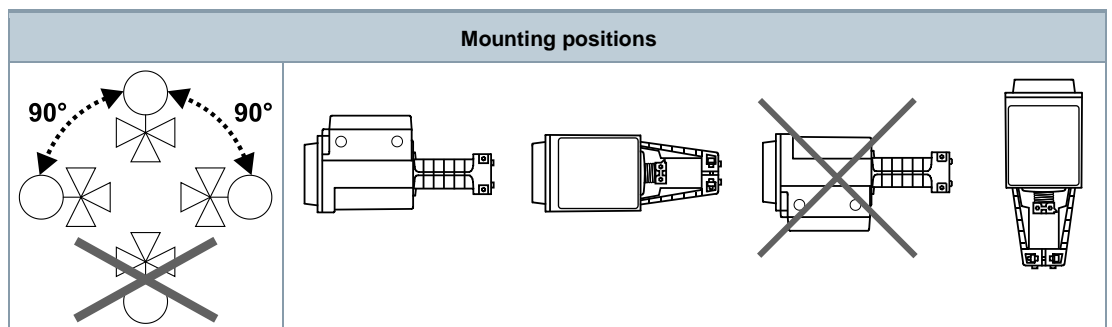

Commissioning

When commissioning the system, check the wiring and functions, and set any auxiliary switches and potentiometers as necessary, or check the existing settings.

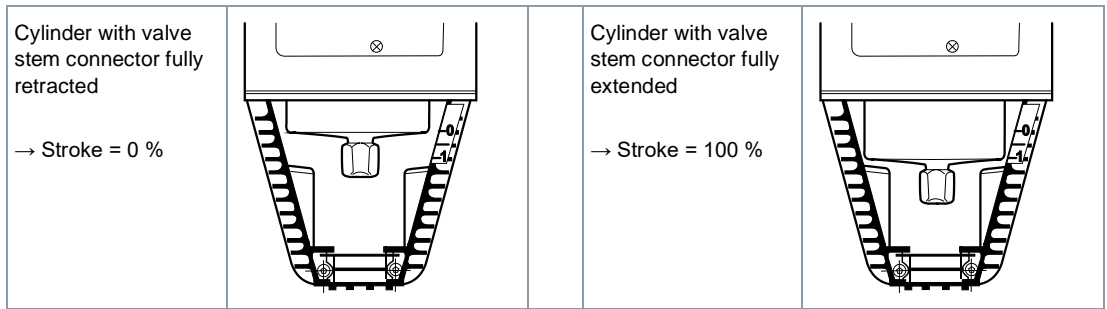

The hand crank must be rotated counter-clockwise to the end stop, in order to close the Siemens valves of the series VVF.. and VXF.. (stroke = 0 %).

Operation

Automatic operation

For automatic operation, the crank [2] on the manual stroke adjuster [1] must be engaged. If not engaged, turn the crank counter-clockwise until the display window [3] shows neither the scale [4] nor the crank engagement bar.

Manual operation

For manual operation, swing out the crank [2] so that the display window [3] becomes visible. By rotating the crank or the manual adjuster [1], the display window shows the engagement bar and/or the scale dial [4] with stroke indication.

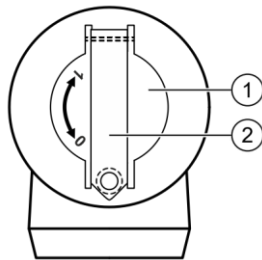

Engaged crank [2] on the manual adjuster [1]

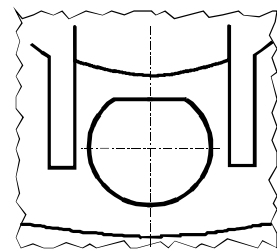

Display window with invisible scale dial and crank engagement bar

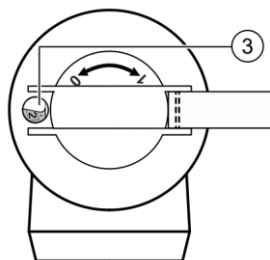

Swung-out crank; display window [3]

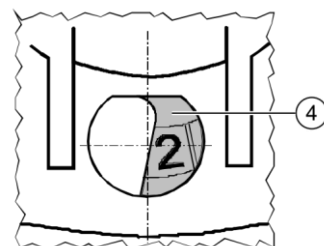

Display window with scale dial [4] and stroke indication in mm

Actuators are maintenance-free.

Servicing the control device:

⚠ WARNING	
	<p>Risk of burns from hot actuator brackets</p> <p>The actuator brackets on heating plants will become hot from contact with the hot valve during operation. The temperature of the actuator bracket can reach 100 °C.</p> <p>When servicing the actuator:</p> <ul style="list-style-type: none">• Switch off both pump and operating voltage.• Close the main shut-off valve in the piping.• Release pressure in the pipes and allow them to cool off completely.

⚠ WARNING	
	<p>Risk of injury</p> <ul style="list-style-type: none">• Disconnect electrical connections from the terminals as needed.• The actuator must be properly installed prior to recommissioning the valve.



Recommendation SKC6..:

Trigger stroke calibration after maintenance.

Repair:

See "Spare parts [▶ 12]"

⚠ WARNING	
	<p>Risk of injury through broken housing or cover</p> <p>Dismounting the actuator with broken housing from the valve can release the highly tensioned spring-return, which can lead to flying parts and injuries.</p> <ul style="list-style-type: none">• NEVER dismount actuator from valve.• Dismount valve-actuator combination (control device) as complete unit.• Disassembly only by qualified personnel.• Send the control device along with an error report to the local Siemens office for analysis and disposal.• Mount new control device (valve and actuator) properly.

Disposal

⚠ WARNING



Tensioned return spring

Opening the actuator housing can release the highly tensioned return spring, which can lead to flying parts and injuries.

- Do not open the actuator housing.



This symbol or any other national label indicate that the product, its packaging, and, where applicable, any batteries may not be disposed of as domestic waste. Delete all personal data and dispose of the item(s) at separate collection and recycling facilities in accordance with local and national legislation.

For additional details, refer to [Siemens information on disposal](#).

Warranty

The application-specific technical data is guaranteed only in combination with the Siemens products listed in the "Equipment combinations" section. If third-party products are used, any guarantee provided by Siemens will be invalidated.

Power supply		
Operating voltage		
	SKC32..	AC 230 V \pm 15 %
	SKC82..	AC 24 V \pm 20 % (SELV/PELV)
	SKC6..	
Frequency		50 / 60 Hz
Maximum power consumption at 50 Hz		
	SKC32.60, SKC32.60/F	18 VA / 14 W
	SKC32.61, SKC32.61/F	24 VA / 18 W
	SKC82.60, SKC82.60U	15 VA / 12 W
	SKC82.61, SKC82.61U	19 VA / 14 W
	SKC60	17 VA / 13 W
	SKC62..	21 VA / 15 W
External supply cable fuse		
	SKC32..	Min. 0.5 A, slow Max. 6 A slow
	SKC82..	Min. 1.6 A, slow Max. 10 A slow
	SKC6..	

Function data			
Positioning time at 50 Hz ¹⁾			
	SKC32..	Opening, Closing	120 s
	SKC82..		
	SKC6..	Opening	120 s
		Closing	20 s
Spring-return time ¹⁾			
	SKC32.61, SKC32.61/F	18 s	
	SKC82.61, SKC82.61U		
	SKC62..	20 s	
Positioning force		2800 N	
Nominal stroke		40 mm	
Maximum permissible medium temperature (fitted valve)		-25...220 °C	
			< 0 °C: Requires stem heater ASZ6.6

Signal inputs / signal outputs			
Control signal			
	SKC32..		3-position
	SKC82..		
	SKC6..		DC 0...10 V
			DC 4...20 mA
			0...1000 Ω
Positioning signal Y (SKC6..)			
	Input impedance	DC 0...10 V	100 kΩ
		DC 4...20 mA	240 Ω
	Signal resolution		< 1 %
	Hysteresis		1 %
Override control Z (SKC6..)			
	Resistor		0...1000 Ω
	Z not connected, priority terminal Y		No function
	Z connected directly to G		Max. stroke 100 %
	Z connected directly to G0		Min. stroke 0 %
	Z connected to M via 0...1000 Ω		Stroke proportional to R
Position feedback U (SKC6..)			
	Load impedance	DC 0...9.8 V	> 10 kΩ
		DC 4...19.6 mA	< 500 Ω

Additional functions SKC60 ²⁾ , SKC62UA			
Selection of direction of operation			
	SKC60, SKC62UA	Direct-acting / reverse-act- ing	DC 0...10 V / DC 10...0 V
			DC 4...20 mA / DC 20...4 mA
			0...1000 Ω / 1000...0 Ω
Stroke limit control			
	SKC62UA	Range of lower limit	0...45 % adjustable
		Range of upper limit	100...55% adjustable
Sequence control		Terminal Y	
	SKC62UA	Start point of sequence	0...15 V adjustable
		Operating range of se- quence	3...15 V adjustable
Signal addition		Z connected to R of	
	SKC62UA	Frost protection monitor QAF21..	0...1000 Ω, added to Y signal
		Frost protection monitor QAF61..	DC 1.6 V, added to Y signal

Communication SKC62/MO		
Communication protocol		
	Modbus RTU	RS-485, not galvanically isolated
	Number of nodes	Max. 32
	Address range	1...245 / 255
	Factory setting	255
	Transmission formats	1-8-E-1 / 1-8-O-1 / 1-8-N-1 / 1-8-N-2
	Factory setting	1-8-E-1
	Baud rate (kBaud)	Auto / 9.6 / 19.2 / 38.4 / 57.6 / 76.8 / 115.2
	Factory setting	Auto
	Bus termination	120 Ω electronically switchable
	Factory setting	Off

Electrical connections and connecting cables		
Wire cross-sectional area		0.5...2.5 mm ² , AWG 21...14 ³⁾
Cable inlet		4 x M20 (∅ 20.5 mm)
	SKC..U	With knockouts for standard ½" conduit connectors (∅ 21.5 mm)
	SKC62/MO	Fixed connection cable
	Cable length	0.9 m
	Number of wires	5 x 0.75 mm ²

Degree and class of protection		
Protection class		As per EN 60730
	Automatic action	Type 1AA / Type 1AC / Modulation Action
	Pollution degree	2
Housing protection upright to sideways		IP54 as per EN 60529

Environmental conditions		
Operation		IEC 60721-3-3 (1994)
	Climatic conditions	Class 3K5
	Temperature, general	-15...55 °C
	Humidity (non-condensing)	5...95 % r.h.
Transportation		IEC 60721-3-2 (1994)
	Climatic conditions	Class 2K3
	Temperature	-30...65 °C
	Humidity (non-condensing)	5...95 % r.h.

Environmental conditions		
Storage		IEC 60721-3-1 (1994)
	Climatic conditions	
	Class 1K3	
	Temperature	-15...55 °C
	Humidity (non-condensing)	-5...95 % r.h.

Directives and standards		
Product standard		EN 60730-x
Electromagnetic compatibility (Applications)		For use in residential, commercial, and industrial environments
EU conformity (CE)		A5W00007751 ⁴⁾
UK conformity (UKCA)		A5W00221181A ⁴⁾
RCM conformity		A5W00007895 ⁴⁾
EAC conformity		Eurasia conformity for all SKC..
UL, cUL	AC 230 V	-
	AC 24 V	UL 873 http://ul.com/database

Environmental compatibility
The product environmental declarations CE1E4566enX1 (SKC32..., SKC82..) ⁴⁾ , CE1E4566enX2 (SKC6..) ⁴⁾ and A6V101083254 (external Modbus converter) ⁴⁾ contain data on environmentally compatible product design and assessments (RoHS compliance, material composition, packaging, environmental benefit, disposal).

Dimensions / Weight			
Dimensions		See "Dimensions [▶ 31]"	
Weight			
	SKC32.60, SKC32.60/F		9.80 kg
	SKC32.61, SKC32.61/F		9.85 kg
	SKC82.60		9.80 kg
	SKC82.60U		10.10 kg
	SKC82.61		9.85 kg
	SKC82.61U		10.15 kg
	SKC60 SKC62, SKC62/MO		9.85 kg
		External Modbus converter	0.15 kg
	SKC62U, SKC62UA		10.15 kg

Materials	
Housing	Die-cast aluminium
Bracket	
Housing box	Plastic
Hand crank	

Accessories			
Auxiliary switch ASC1.6			
	SKC6..	Switching capacity	AC 24 V / 10 mA....4 A resistive / 2 A inductive
Double auxiliary switch ASC9.3			
	SKC32.., SKC82..	Switching capacity per auxiliary switch	AC 250 V / 6 A resistive / 2.5 A inductive
Potentiometer ASZ7.3			
	SKC32.., SKC82..	Change in overall resistance of potentiometer at nominal stroke	0...1000 Ω
Stem heater ASZ6.6			
		Operating voltage	AC 24 V ± 20 %
		Power consumption	40 VA / 30 W
		Inrush current	Max. 8.5 A (Max. temperature 85 °C / 185 °F)

- 1) At room temperature (23 °C); low ambient temperatures or high Δp may prolong these times.
- 2) From version ..L onward
- 3) AWG = American wire gauge
- 4) The documents can be downloaded at <http://www.siemens.com/bt/download>

SKC32..

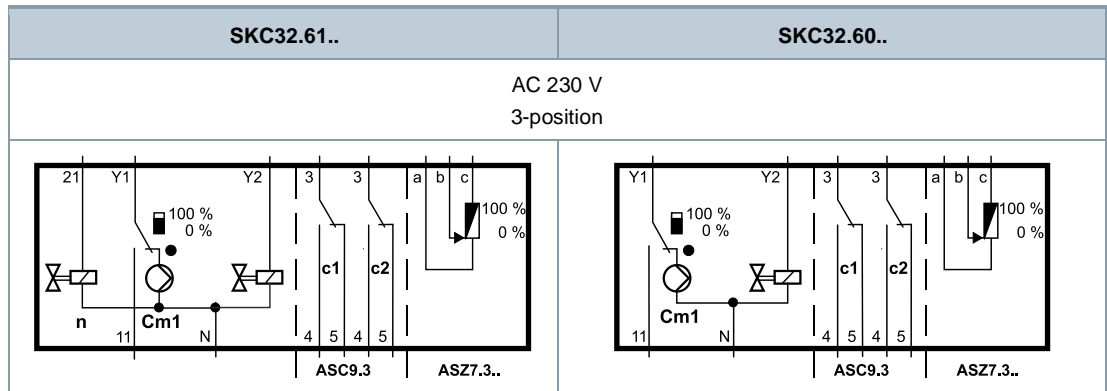

- | | |
|--|--|
| <p>Cm1 End switch</p> <p>n Solenoid valve for spring-return</p> <p>c1, c2 ASC9.3 double auxiliary switch</p> <p>a, b, c ASZ7.3 potentiometer</p> | <p>Y1 Positioning signal "open"</p> <p>Y2 Positioning signal "close"</p> <p>21 Spring-return function</p> <p>N Neutral conductor</p> |
|--|--|

SKC82..

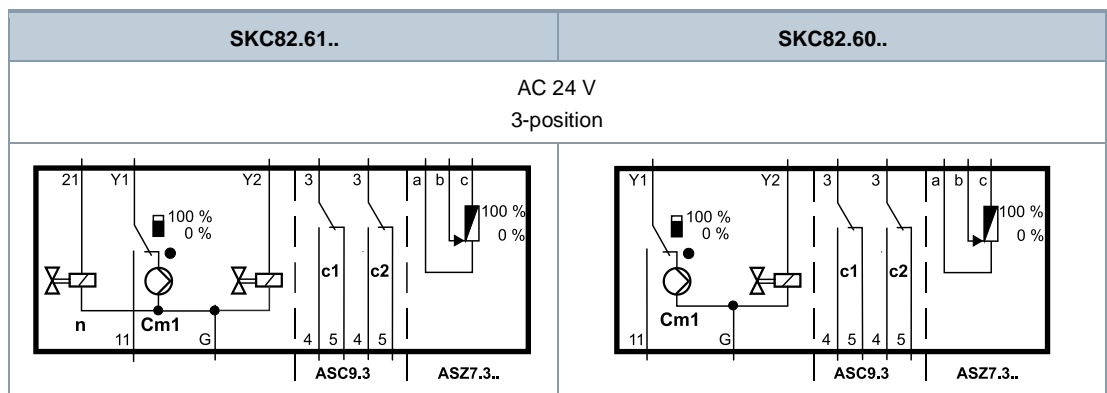

- | | |
|--|---|
| <p>Cm1 End switch</p> <p>n Solenoid valve for spring-return</p> <p>c1, c2 ASC9.3 double auxiliary switch</p> <p>a, b, c ASZ7.3 potentiometer</p> | <p>Y1 Positioning signal "open"</p> <p>Y2 Positioning signal "close"</p> <p>21 Spring-return function</p> <p>G System potential</p> |
|--|---|

SKC6..

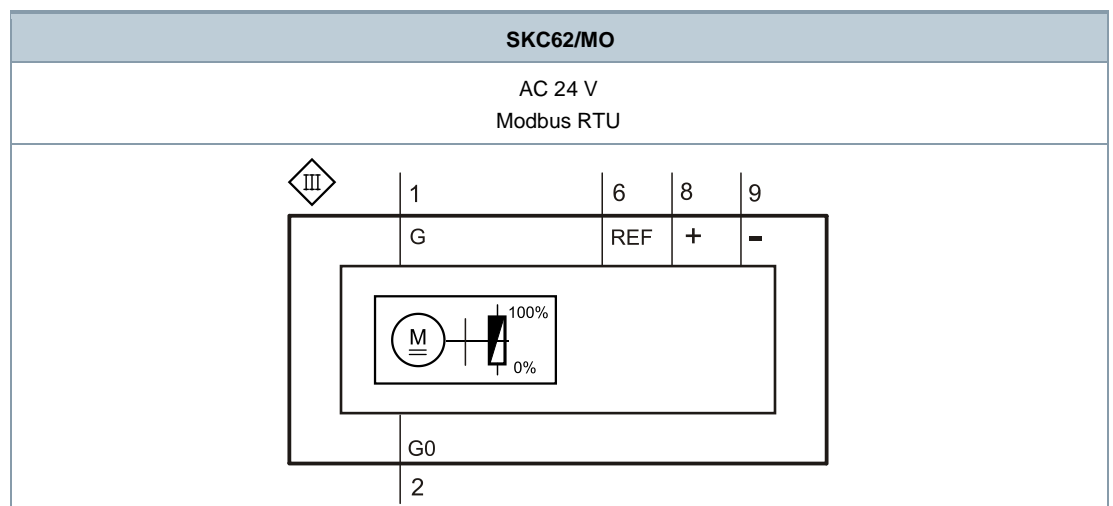
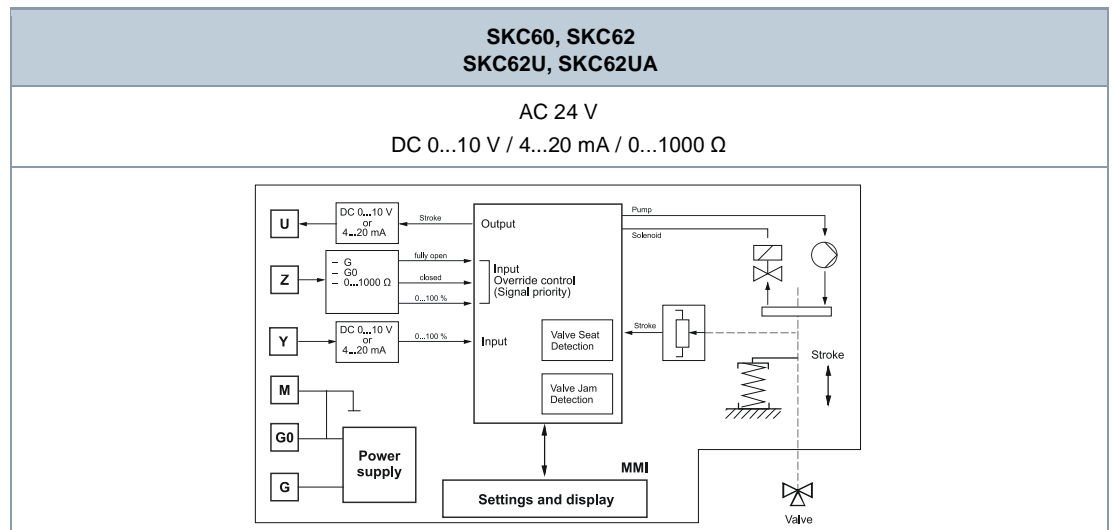

U	Position feedback	REF	Reference (Modbus RTU)
Z	Override control	+	Bus + (Modbus RTU)
Y	Positioning signal	-	Bus - (Modbus RTU)
M	Measuring neutral		
	G0		Operating voltage AC 24 V: System neutral (SN)
	G		Operating voltage AC 24 V: System potential (SP) De-energize for spring-return function

SKC6..

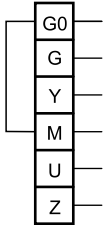
	AC 24 V	DC 0...10 V / 4...20 mA / 0...1000 Ω
	System neutral (SN)	
	System potential (SP)	
	Positioning signal DC 0...10 (30) V or DC 4...20 mA	
	Measuring neutral (= G0)	
	Position feedback DC 0...10 V or DC 4...20 mA	
	Override control ("Functions [► 7]")	

SKC62/MO

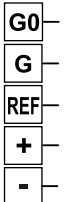
	AC 24 V	Modbus RTU connecting cable
	System neutral (SN)	black
	System potential (SP)	red
	Reference line (Modbus RTU)	purple
	Bus + (Modbus RTU)	gray
	Bus - (Modbus RTU)	pink

Auxiliary switch ASC1.6

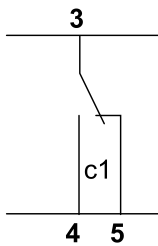

SKC32..

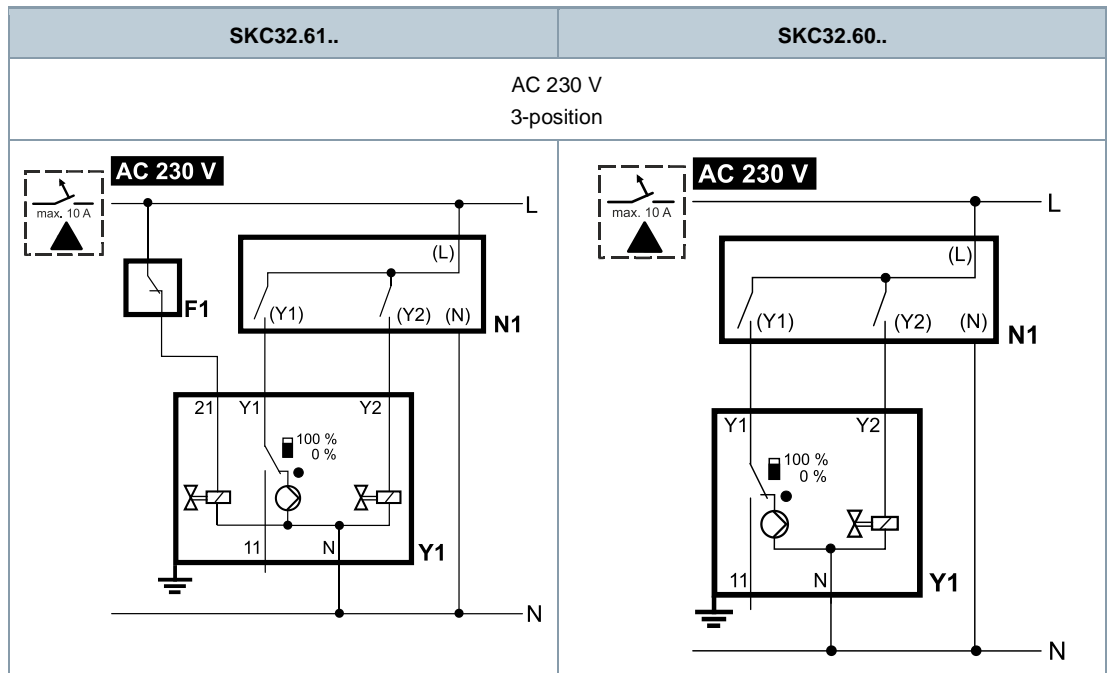

F1 Safety limiter (e.g. temperature limiter)

N1, N2 Controller

Y1, Y2 Actuators

L Phase

N Neutral

Y1 Positioning signal "open"

Y2 Positioning signal "close"

21 Spring-return function

SKC82..

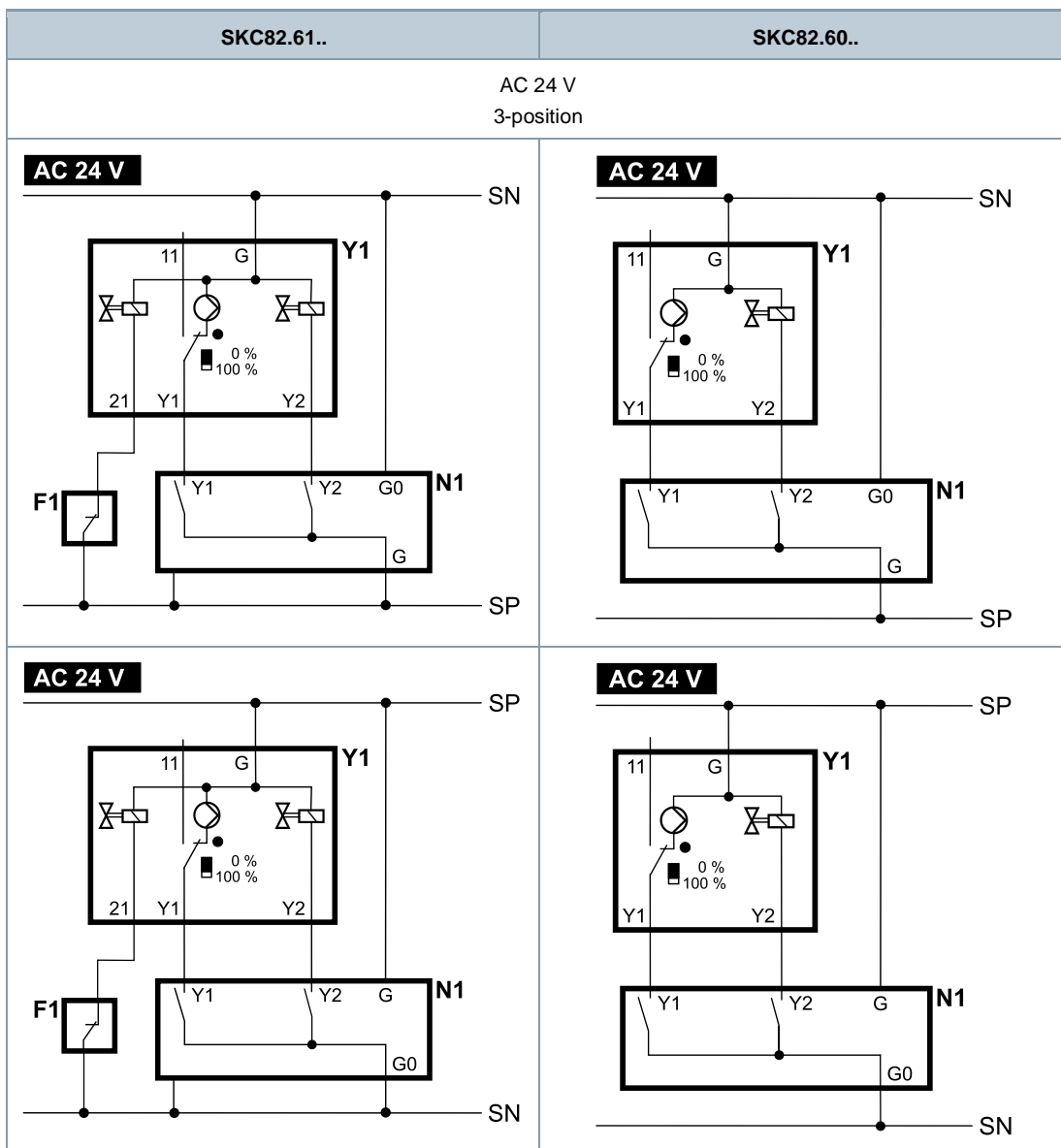

F1 Safety limiter (e.g. temperature limiter)

SP System potential AC 24 V

N1, N2 Controller

SN System neutral

Y1, Y2 Actuators

(Y1), (Y2) Controller contacts

Y1 Positioning signal "open"

Y2 Positioning signal "close"

21 Spring-return function

SKC6..

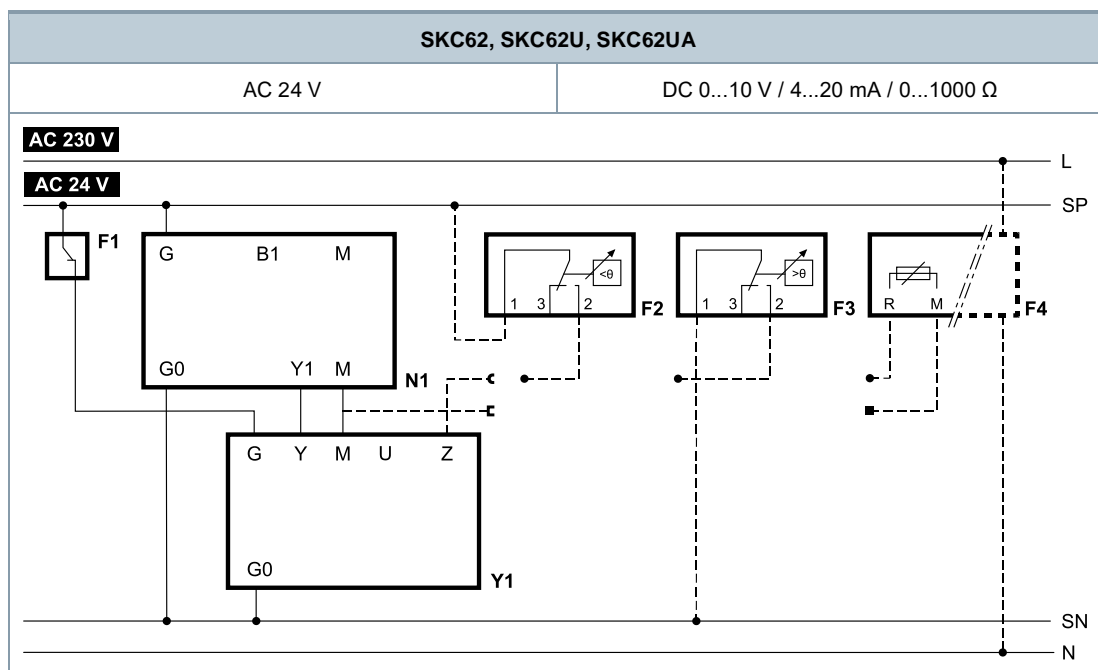
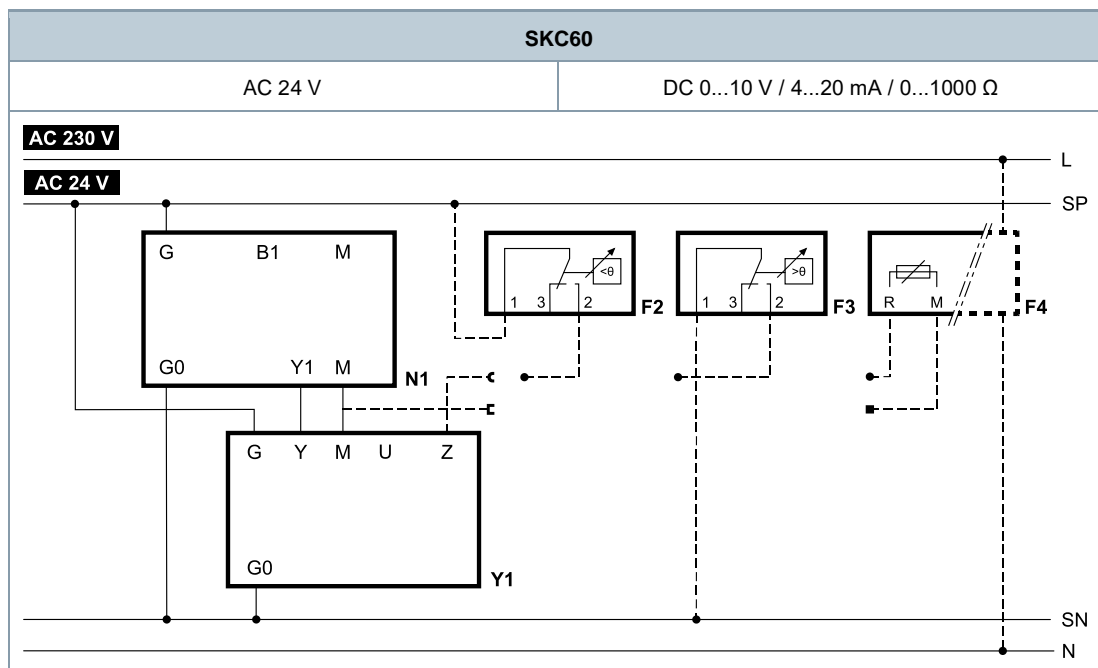

- | | | | |
|-----------|---|--|---|
| Y1 | Actuator | F3 | Temperature detector |
| N1 | Controller | F4 | Frost protection monitor with 0...1000 Ω signal output, e.g. QAF21.. or QAF61.. (SKC62UA) only *) |
| F1 | Safety limiter (e.g. temperature limiter) | G (SP) | System potential AC 24 V |
| F2 | Frost protection thermostat | G0 (SN) | System neutral |
| Terminals | 1-2 | Frost hazard/sensor is interrupted (closes with frost) | |
| | 1-3 | Normal operation | |

*) Only SKC62UA: only with sequence control and the appropriate rotary switch settings, see "Electronics [▶ 5]", "Functions [▶ 6]"

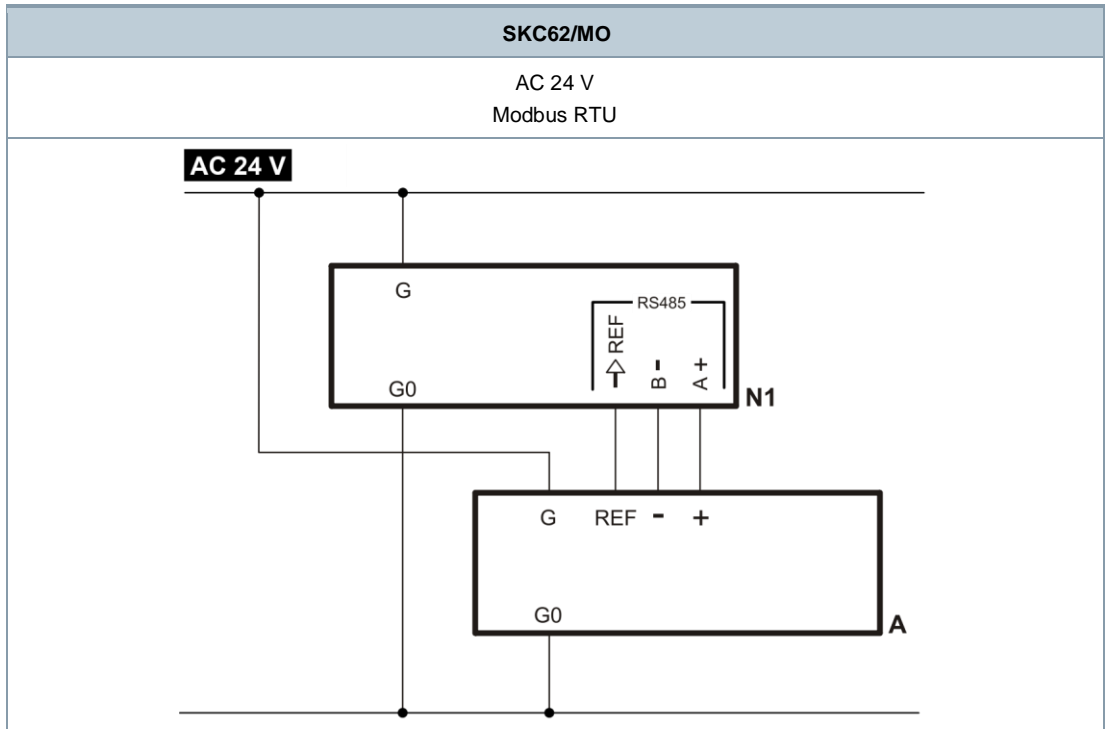

A	Actuator	REF	Reference (Modbus RTU)
N1	Controller	+	Bus + (Modbus RTU)
G	System potential	-	Bus - (Modbus RTU)
G0	System neutral		

NOTICE



Using safety limiter F1

When using a safety limiter F1, ensure that no mistakes occur when insulating cables that may cancel out the temperature limiter function (applies to both 230 V as well as 24 V types).

- For SN grounding (e.g. PELV), comply under all circumstances with the note above.

Actuator

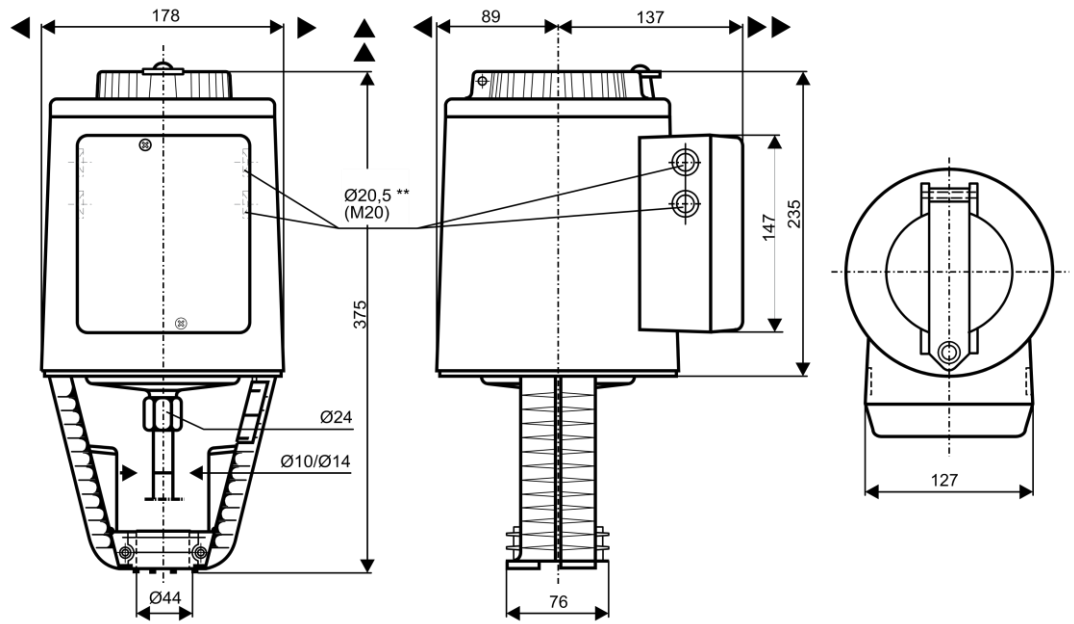

Dimensions in mm

** SKC..U: with knockouts for standard 1/2" conduit connectors (Ø 21.5 mm)

- ▶ > 100 mm, minimum clearance from ceiling or wall for mounting
- ▶▶ > 200 mm, for connection, operation, maintenance, etc.

External Modbus converter

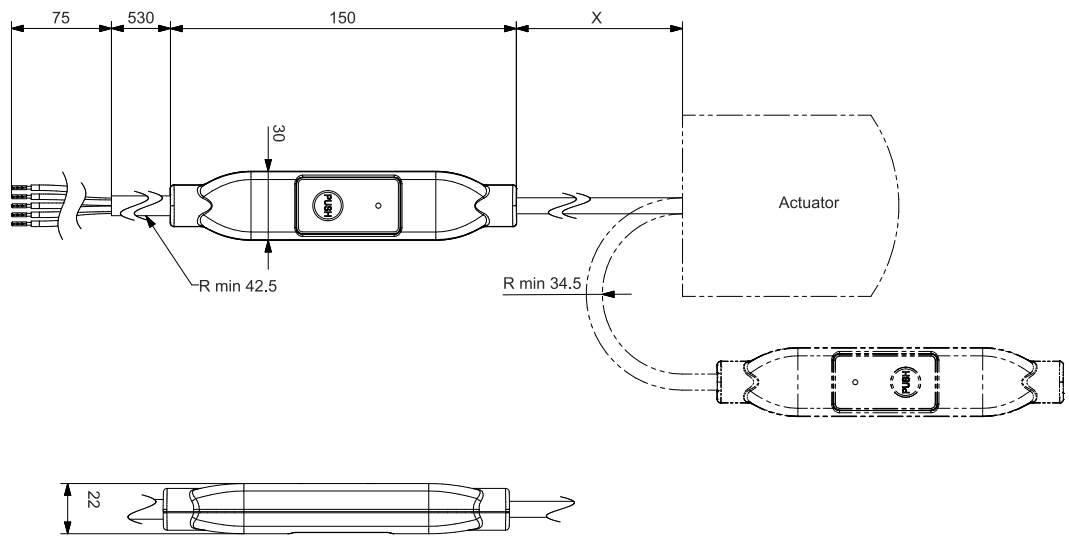

Dimensions in mm

X 250 mm

Revision numbers

Type	Valid from rev no.	Type	Valid from rev no.
SKC32.60	..D	SKC60	..G
SKC32.60/F	..D	SKC62	..G
SKC32.61	..D	SKC62/F	..G
SKC32.61/F	..D	SKC62U	..G
SKC82.60	..D	SKC62UA	..G
SKC82.60U	..D	SKC62/MO	..H
SKC82.61	..D		
SKC82.61U	..D		

Issued by
Siemens Switzerland Ltd
Smart Infrastructure
Global Headquarters
Theilerstrasse 1a
CH-6300 Zug
+41 58 724 2424
www.siemens.com/buildingtechnologies

© Siemens 1998 - 2024
Technical specifications and availability subject to change without notice.

Document ID CM1N456en
Edition 2024-11-27